



# FORNITURE ALBERGHIERE

*HOTEL SUPPLIES*



**GENNAIO 2024**



Le immagini sono fornite al solo scopo illustrativo, non costituiscono elemento contrattuale.

Copyright © 2024 STARK S.r.l.

**Rev. 01 • Gennaio 2024**

Tutti i diritti riservati.

Il presente catalogo è stato redatto con la massima attenzione e precisione rispetto all'accuratezza di informazioni e dati tecnici, tuttavia si declina ogni responsabilità per errori, omissioni o variazioni che possano esservi riscontrati.

*Images are provided for illustration purposes only and do not constitute a contractual element.*

Copyright © 2024 STARK S.r.l.

**Rev. 01 • January 2024**

All rights reserved.

*This catalogue has been compiled with the utmost attention and precision as regards the accuracy of the information and technical data. The company nevertheless disclaims all liability for any errors, omissions or changes.*



MINIBAR & ACCESSORI..... <i>Minibar &amp; accessories</i>	4
CASSEFORTI..... <i>Hotel safe</i>	16
SERRATURE..... <i>Locks</i>	26
ASCIUGACAPELLI..... <i>Hair dryers</i>	30
ASCIUGAMANI AD ARIA..... <i>Hand dryers</i>	36
ATTREZZATURE COLAZIONE..... <i>Breakfast equipment</i>	40
PORTA VALIGIE..... <i>Luggage rack</i>	46
ATTREZZATURE DI SERVIZIO..... <i>Service equipment</i>	52
PATTUMIERE..... <i>Dustbins</i>	58
ARREDO BAGNO..... <i>Bathroom furniture</i>	68
ARREDO CAMERE..... <i>Furniture for bedroom</i>	78
COLONNINE SEGNAPERCORSO..... <i>Crowd control post</i>	86
LAMPADE..... <i>Lamps</i>	90
RISCALDAMENTO PER ESTERNO..... <i>Outdoor heating</i>	98
PIANTE ARTIFICIALI..... <i>Artificial plants</i>	102
PULIZIE E SANIFICAZIONE..... <i>Cleaning &amp; sanitization</i>	110
PICCOLI ELETTRODOMESTICI..... <i>Small appliances</i>	118
CATERING..... <i>Catering</i>	128



# MINIBAR & ACCESSORI

*Minibar & accessories*



# MINIBAR



**Nuova tecnologia di raffreddamento a pompa di calore a stato solido.**

*New cooling technology solid state heat pump.*



**Alta efficienza di raffreddamento.**

*High cooling efficiency.*



**Elevato risparmio energetico ed assenza assoluta di rumore per il massimo comfort in camera.**

*High energy saving and absolute absence of noise for the maximum comfort in the room.*



**BASSO CONSUMO  
ENERGETICO**

*LOW ENERGY CONSUMPTION*



**SENZA  
AMMONIACA**

*WITHOUT AMMONIA*



**RUMOROSITÀ  
0 dB**

*0 dB NOISE*



**CLASSI ENERGETICHE RICODIFICATE SECONDO NUOVA NORMATIVA EUROPEA.**  
*RE-ENCODED ENERGY CLASSES ACCORDING TO NEW EUROPEAN LEGISLATION.*



## MINIBAR CON PORTA CIECA 28 LITRI

*MINIBAR WITH BLIND DOOR,  
28 LITERS*

COD **E28**

Minibar con porta pannellata, colore nero. Classe energetica E (ex A+). Rumorosità 0 dB. Consumo annuale 78 kWh/annum. Consumo giornaliero 0,214 kWh/24h. Refrigerazione R600a con defrost automatico. Potenza 65 W. Voltaggio 220-240 V, 50-60 Hz.

Porta reversibile, illuminazione interna a LED, 1 ripiano interno e rastrelliera lato porta. Presa Schuko e piedini di fissaggio. Certificazioni CE/ROHS.

*Minibar with paneled door, black color. Energy class E (ex A+). Noise 0 dB. Annual consumption 78 kWh/annum. Daily consumption 0,214 kWh/24h. Refrigeration R600a with automatic defrost. Power 65 W. Voltage 220-240 V, 50-60 Hz. Reversible door, internal LED lighting, 1 internal shelf and door rack. Schuko plug and fixing feet. Certifications CE/ROHS.*



### MISURE

**esterne**  
| 38,5 x p 38,5 x h 47,5 cm

**interne**  
| 31 x p 22 x h 37,5 cm



peso netto /  
net weight  
**9,2 kg**



peso lordo /  
gross weight  
**10,4 kg**



capacità lorda /  
gross capacity  
**28 lt**

## MINIBAR CON PORTA A VETRO 28 LITRI

MINIBAR WITH GLASS DOOR, 28 LITERS

COD **E28VN**



Minibar con porta a vetro. Classe energetica D (ex A). Rumorosità 0 dB. Consumo annuale 61 kWh/annum. Consumo giornaliero 0,164 kWh/24H. Refrigerazione R600a con defrost automatico. Potenza 63 W / Voltaggio 110V-250V,50-60/HZ. Porta reversibile, illuminazione interna a LED, 1 ripiano interno. Certificazioni CE/ROHS.

*Minibar with glass door. Energy class D (ex A). Noise level 0 dB. Annual consumption 61 kWh/annum. Daily consumption 0.164 kWh/24H. Refrigeration R600a with automatic defrost. Power 63 W / Voltage 110V-250V, 50-60/HZ. Reversible door, internal LED lighting, 1 internal shelf. Certifications CE/ROHS.*

MISURE	esterne	interne
	l 38,5 x p 38,5 x h 48,5 cm	l 31 x p 23x h 37,5 cm

 peso netto / net weight	 peso lordo / gross weight	 capacità lorda / gross capacity
<b>12,3 kg</b>	<b>13,4 kg</b>	<b>28 lt</b>

## MINIBAR CON PORTA CIECA 30 LITRI

MINIBAR WITH BLIND DOOR, 30 LITERS

COD **E30N**



Minibar con porta pannellata, colore nero. Classe energetica E (ex A+). Rumorosità 0 dB. Consumo annuale 77 kWh/annum. Consumo giornaliero 0,203 kWh/24h. Refrigerazione R600a con defrost automatico. Potenza 58 W. Voltaggio 220V, 50 Hz.

Porta reversibile, illuminazione interna a LED, 1 ripiano interno e rastrelliera lato porta. Presa Schuko e piedini di fissaggio. Certificazioni CE/ROHS.

*Minibar with paneled door, black color. Energy class E (ex A+). Noise 0 dB. Annual consumption 77 kWh/annum. Daily consumption 0,203 kWh/24h. Refrigeration R600a with automatic defrost. Power 65 W. Voltage 220V, 50 Hz. Reversible door, internal LED lighting, 1 internal shelf and door rack. Schuko plug and fixing feet. Certifications CE/ROHS.*

MISURE	esterne	interne
	l 38,5 x p 42 x h 47,5 Cm	l 30,5 x p 24,7 x h 37,5 cm

 peso netto / net weight	 peso lordo / gross weight	 capacità lorda / gross capacity
<b>10,5 kg</b>	<b>11,8 kg</b>	<b>30 lt</b>



## MINIBAR CON PORTA A VETRO 35 LITRI



MINIBAR WITH GLASS DOOR,  
35 LITERS

COD **E30VN\***

Minibar con porta a vetro triplo strato. Sistema di raffreddamento termoelettrico a tubi di calore. Classe energetica F (ex A). Rumorosità 0 dB. Refrigerazione R600a. Consumo annuale 95 kWh/annum. Potenza 60 W / Voltaggio 100-240 V, ~50/60 Hz. Porta reversibile, illuminazione interna a LED, 2 ripiani interni in vetro. Certificazioni CE/ROHS. Presa Schuko. Piedini di fissaggio.

*Minibar with three-layer glass door. Thermoelectric heat pipe cooling system. Energy class F (ex A). Noise 0 dB. Refrigeration R600a. Annual consumption 95 kWh/annum. Power 60 W / Voltage 100-240 V, ~50/60 Hz. Reversible door, internal LED lighting, 2 glass internal shelves. Certifications CE/ROHS. Schuko plug. Fixing feet.*

MISURE	esterne	interne
	l 40 x p 42 x h 50 cm	l 32,5 x p 25,5 x h 40 cm

 peso netto / net weight	 peso lordo / gross weight	 capacità lorda / gross capacity
<b>15 kg</b>	<b>16,2 kg</b>	<b>35 lt</b>



## MINIBAR CON PORTA A VETRO 30 LITRI



MINIBAR WITH GLASS DOOR,  
30 LITERS

COD **E30VN**

Minibar con porta a vetro triplo strato. Sistema di raffreddamento termoelettrico a tubi di calore. Classe energetica E (ex A). Rumorosità 0 dB. Refrigerazione R600a. Consumo annuale 76 kWh/annum. Potenza 60 W / Voltaggio 220-240 V, ~50/60 Hz. Temperatura media: 8-15 °C. Porta reversibile, illuminazione interna a LED, 1 ripiano interno in vetro. Certificazioni CE/EMC/CCC/ROHS. Presa BS/VDE/USA/SA/CCC/South Africa/Swiss. Piedini di fissaggio.

*Minibar with three-layer glass door. Thermoelectric heat pipe cooling system. Energy class E (ex A). Noise 0 dB. Refrigeration R600a. Annual consumption 76 kWh/annum. Power 60 W / Voltage 220-240 V, ~50/60 Hz. Average temperature: 8-15 °C. Reversible door, internal LED lighting, 1 glass internal shelf. Certifications CE/EMC/CCC/ROHS. BS/VDE/USA/SA/CCC/South Africa/Swiss plug. Fixing feet.*

MISURE	esterne	interne
	l 38,5 x p 42 x h 48,5 cm	l 31 x p 28,5 x h 37,5 cm

 peso netto / net weight	 peso lordo / gross weight	 capacità lorda / gross capacity
<b>12,5 kg</b>	<b>13,8 kg</b>	<b>30 lt</b>





## MINIBAR CON PORTA A SPECCHIO FUMÈ 35 LITRI

MINIBAR WITH FUMÈ MIRROR DOOR, 35 LITERS

COD **E30M\***



Minibar con porta a vetro triplo strato. Cornice e corpo in finitura nero lucido, porta in E-glass. Classe energetica G (ex A). Rumorosità 0 dB. Consumo annuale 129 kWh/annum. Consumo giornaliero 0,353 kWh/24h. Refrigerazione R600a con defrost automatico. Potenza 60 W. Voltaggio 220-240 V, ~50 Hz. Illuminazione interna a LED, 2 ripiani interni in vetro. Presa Schuko. Certificazioni CE/ROHS.

Minibar with three-layer glass door. Frame and body with glossy black color finishing. Energy class G (ex A). Noise 0 dB. Annual consumption 129 kWh/annum. Daily consumption 0,353 kWh/24h. Refrigeration R600a with automatic defrost. Power 60 W. Voltage 220-240 V, ~50 Hz. Internal LED lighting, 2 glass internal shelves. Schuko plug. Certifications CE/ROHS.

MISURE	esterne	interne
	l 34,5 x p 48,5 x h 46 cm	l 26 x p 31 x h 36,5 cm

 peso netto / net weight	 peso lordo / gross weight	 capacità lorda / gross capacity
<b>13,1 kg</b>	<b>14,7 kg</b>	<b>35 lt</b>

## MINIBAR BIANCO CON PORTA A VETRO 35 LITRI

WHITE MINIBAR WITH GLASS DOOR, 35 LITERS

COD **E30VW\***



Minibar con porta a vetro triplo strato. Cornice e corpo in finitura bianca, porta in E-glass. Classe energetica G (ex A). Rumorosità 0 dB. Consumo annuale 129 kWh/annum. Consumo giornaliero 0,353 kWh/24h. Refrigerazione R600a con defrost automatico. Potenza 60 W. Voltaggio 220-240 V, ~50 Hz. Porta reversibile, illuminazione interna a LED, 2 ripiani interni in vetro. Presa Schuko. Certificazioni CE/ROHS.

Minibar with three-layer glass door. Frame and body with white color finishing, E-glass. Energy class G (ex A). Noise 0 dB. Annual consumption 129 kWh/annum. Daily consumption 0,353 kWh/24h. Refrigeration R600a with automatic defrost. Power 60 W. Voltage 220-240 V, ~50 Hz. Reversible door, internal LED lighting, 2 glass internal shelves. Schuko plug. Certifications CE/ROHS.

MISURE	esterne	interne
	l 34,5 x p 48,5 x h 46 cm	l 26 x p 31 x h 36,5 cm

 peso netto / net weight	 peso lordo / gross weight	 capacità lorda / gross capacity
<b>13,1 kg</b>	<b>14,7 kg</b>	<b>35 lt</b>



## MINIBAR CON PORTA CIECA 40 LITRI

MINIBAR WITH BLIND DOOR,  
40 LITERS

COD **E40**

Minibar con porta pannellata, colore nero. Classe energetica E (ex A+). Rumorosità 0 dB. Consumo annuale 96 kWh/annum. Consumo giornaliero 0,263 kWh/24h. Refrigerazione R600a con defrost automatico. Potenza 63 W. Voltaggio 220-240 V, 50-60 Hz.

Porta reversibile, illuminazione interna a LED, 2 ripiani interni e rastrelliera lato porta. Presa Schuko e piedini di fissaggio. Certificazioni CE/ROHS.

*Minibar with paneled door, black color. Energy class E (ex A+). Noise 0 dB. Annual consumption 96 kWh/annum. Daily consumption 0,263 kWh/24h. Refrigeration R600a with automatic defrost. Power 65 W. Voltage 220-240 V, 50-60 Hz. Reversible door, internal LED lighting, 2 internal shelves and door rack. Schuko plug and fixing feet. Certifications CE/ROHS.*



MISURE	esterne	interne
	l 40 x p 42,5 x h 56 cm	l 30 x p 25 x h 46,5 cm

 peso netto /  
net weight  
**12,3 kg**

 peso lordo /  
gross weight  
**13,7 kg**

 capacità lorda /  
gross capacity  
**40 lt**

## MINIBAR CON PORTA A VETRO 40 LITRI

MINIBAR WITH GLASS DOOR,  
40 LITERS

COD **E40V\***

Minibar con porta a vetro triplo strato. Cornice e corpo in finitura nera. Porta in E-glass. Classe energetica G (ex A). Rumorosità 0 dB. Consumo annuale 176 kWh/annum. Consumo giornaliero 0,482 kWh/24h. Refrigerazione R600a con defrost automatico. Potenza 60 W. Voltaggio 220V-240 V, ~50 Hz. Porta reversibile, illuminazione interna a LED, 2 ripiani interni in vetro. Presa Schuko. Certificazioni CE/ROHS.

*Minibar with three-layer glass door. Frame and body with black color finishing, E-glass. Energy class G (ex A). Noise 0 dB. Annual consumption 176 kWh/annum. Daily consumption 0,482 kWh/24h. Refrigeration R600a with automatic defrost. Power 60 W. Voltage 220V-240 V, ~50 Hz. Reversible door, internal LED lighting, 2 glass internal shelves. Schuko plug. Certifications CE/ROHS.*



MISURE	esterne	interne
	l 43 x p 41,5 x h 50 cm	l 35 x p 23 x h 40,5 cm

 peso netto /  
net weight  
**14,7 kg**

 peso lordo /  
gross weight  
**15,8 kg**

 capacità lorda /  
gross capacity  
**40 lt**

## MINIBAR SISTEMA PELTIER CON PORTA A VETRO, 40 LITRI

PELTIER SYSTEM MINIBAR WITH GLASS DOOR 40 LITERS

COD **E40VBN**



Minibar sistema Peltier con porta a vetro, interno ed esterno colore nero. Classe energetica D (ex A). Rumorosità 0 dB. Consumo annuale 60 kWh/annum. Consumo giornaliero 0,164 kWh/24h. Refrigerazione R600a con defrost automatico. Potenza 63 W. Voltaggio 100V-127V, 220V-240V,50-60 Hz. Temperatura media: 5-12 C°.

Illuminazione interna a LED, 2 ripiani interni in vetro. Presa BS/VDE/USA/SAA/CCC/South Africa/Swiss. Certificazioni CE/EMC/CCC/ROHS.

*Peltier system minibar with glass door, black interior and exterior color. Energy class D (ex A). Noise 0 dB. Annual consumption 60 kWh/annum. Daily consumption 0,164 kWh/24h. Refrigeration R600a with automatic defrost. Power 60 W. 100V-127V, 220V-240V,50-60 Hz. Average temperature: 5-12 C°. Internal LED lighting, 2 glass internal shelves. BS/VDE/USA/SAA/CCC/South Africa/Swiss plug. Certifications CE/EMC/CCC/ROHS.*

MISURE	esterne	interne
	l 42 x p 40 x h 57 cm	l 30 x p 26 x h 46,5 cm

 peso netto / net weight	 peso lordo / gross weight	 capacità lorda / gross capacity
<b>15,5 kg</b>	<b>17 kg</b>	<b>40 lt</b>

## MINIBAR SISTEMA PELTIER CON PORTA A VETRO, 40 LITRI

PELTIER SYSTEM MINIBAR WITH GLASS DOOR 40 LITERS

COD **E40VN**



Minibar sistema Peltier con porta a vetro, colore nero. Classe energetica D (ex A). Rumorosità 0 dB. Consumo annuale 60 kWh/annum. Consumo giornaliero 0,164 kWh/24h. Refrigerazione R600a con defrost automatico. Potenza 63 W. Voltaggio 100V-127V, 220V-240V,50-60 Hz. Temperatura media: 5-12 C°.

Porta reversibile, illuminazione interna a LED, 2 ripiani interni in vetro. Presa BS/VDE/USA/SAA/CCC/South Africa/Swiss. Certificazioni CE/EMC/CCC/ROHS.

*Peltier system minibar with glass door, black color. Energy class D (ex A). Noise 0 dB. Annual consumption 60 kWh/annum. Daily consumption 0,164 kWh/24h. Refrigeration R600a with automatic defrost. Power 63 W. Voltage 100V-127V, 220V-240V, 50-60 Hz. Average temperature: 5-12 C°. Reversible door, internal LED lighting, 2 glass internal shelves. BS/VDE/USA/SAA/CCC/South Africa/Swiss plug. Certifications CE/EMC/CCC/ROHS.*

MISURE	esterne	interne
	l 40 x p 42,5 x h 57 cm	l 30 x p 26 x h 46,5 cm

 peso netto / net weight	 peso lordo / gross weight	 capacità lorda / gross capacity
<b>15,5 kg</b>	<b>17 kg</b>	<b>40 lt</b>



## MINIBAR A COMPRESSORE CON PORTA CIECA 40 LITRI

COMPRESSOR MINIBAR WITH  
BLIND DOOR, 40 LITERS

COD **C40**

Minibar a compressore con porta pannellata, colore nero. Classe energetica D (ex A+++). Rumorosità 38 dB (0 dB in modalità sleep). Consumo annuale 59 kWh/annum. Consumo giornaliero 0,159 kWh/24h. Refrigerazione R600a con defrost automatico. Potenza 60 W. Voltaggio 220-240 V, 50-60 Hz. Temperatura media: sotto i 5°C (temperatura ambiente 32°C). Illuminazione interna a LED, 2 ripiani interni e rastrelliera lato porta. Presa Schuko e piedini di fissaggio. Certificazioni CE/CEEI.

*Compressor minibar with paneled door, black color. Energy class D (ex A+++). Noise 38 dB (0 dB in sleep mode). Annual consumption 59 kWh/annum. Daily consumption 0,159 kWh/24h. Refrigeration R600a with automatic defrost. Power 60 W. Voltage 220-240 V, 50-60 Hz. Average temperature: below 5 °C (room temperature 32 °C). Internal LED lighting, 2 internal shelves and door rack. Schuko plug and fixing feet. Certifications CE/CEEI.*



MISURE	esterne	interne
	140 x p 48,5 x h 55,5 cm	132 x p 22,7 x h 45,4 cm

 peso netto / net weight	 peso lordo / gross weight	 capacità lorda / gross capacity
<b>18 kg</b>	<b>19 kg</b>	<b>40 lt</b>

## MINIBAR A CASSETTO 21 LITRI

MINIBAR WITH DRAWER,  
21 LITERS

COD **ED45#**

Tecnologia di raffreddamento con pompa di calore a stato solido. Rumorosità 0 dB. Consumo annuale 85 kWh/annum. Consumo giornaliero 0,228 kWh/24h. Refrigerazione R600a con defrost automatico. Potenza 60 W. Voltaggio 220-240 V, 50-60Hz. Illuminazione interna a LED. Presa Schuko. Piedini fissi senza foro di fissaggio. Maniglia smontabile. Non adatto a contenere bottiglie di 750 ml. Certificazioni CE.

*Cooling technology with solid state heat pump. Noise 0 dB. Annual consumption 85 kWh/annum. Daily consumption 0,228 kWh/24h. Refrigeration R600a with automatic defrost. Power 60 W. Voltage 220-240 V, 50-60 Hz. Internal LED lightings. Schuko plug. Fixed feet without fixing holes. Removable handle. Not suitable for 750 ml bottles. Certifications CE.*



MISURE	esterne	cassetto estraibile
	138,5 x p 43,5 x h 38 cm	127 x p 24,5 x h 23 cm

 peso netto / net weight	 peso lordo / gross weight	 capacità lorda / gross capacity
<b>9,5 kg</b>	<b>11,5 kg</b>	<b>21 lt</b>



## MINIBAR A CASSETTO 45 LITRI

MINIBAR WITH DRAWER,  
45 LITERS

COD **ED45**

Tecnologia di raffreddamento con pompa di calore a stato solido. Classe energetica F (ex A+). Rumorosità 0 dB. Consumo giornaliero 0,27 kWh/24h. Refrigerazione R600a con defrost automatico. Potenza 65 W. Voltaggio 100-127-220-240 V, ~50 Hz. Illuminazione interna a LED. Presa Schuko. Certificazioni CE.

*Cooling technology with solid state heat pump. Energy class F (ex A+). Noise 0 dB. Daily consumption 0,27 kWh/24h. Refrigeration R600a with automatic defrost. Power 65 W. Voltage 100-127-220-240 V, ~50 Hz. Internal LED lightings. Schuko plug. Certifications CE.*

<b>MISURE</b>	<b>esterne</b>
	l 49,7 x p 45,7 x h 42,7cm

 peso netto / net weight	 peso lordo / gross weight	 capacità lorda / gross capacity
<b>11,5 kg</b>	<b>12,5 kg</b>	<b>45 lt</b>

DISPONIBILE SU ORDINAZIONE  
AVAILABLE ON REQUEST



## MINIBAR SLIM A PARETE 12 LITRI

WALL MOUNTING SLIM MINIBAR,  
12 LITERS

COD **EF12#**

Minibar con finitura a specchio. Rumorosità 0 dB. Consumo giornaliero 0,213 kWh/24h. Refrigerazione R600a con defrost automatico. Potenza 60 W. Voltaggio 220-240 V, 50-60 Hz. Porta reversibile, illuminazione interna a LED. Presa Schuko. Staffe e 6 tasselli per fissaggio a parete. Certificazioni CE.

*Minibar with mirror finish. Noise 0 dB. Daily consumption 0,213 kWh/24h. Refrigeration R600a with automatic defrost. Power 60 W. Voltage 220-240 V, 50-60 Hz. Reversible door, internal LED lightings. Schuko plug. Brackets and 6 dowels for wall mounting. Certifications CE.*

<b>MISURE</b>	<b>esterne</b>	<b>interne</b>
	l 40 x p 24,5 x h 53 cm	l 28,5 x p 7 x h 42 cm

 peso netto / net weight	 peso lordo / gross weight	 capacità lorda / gross capacity
<b>12,5 kg</b>	<b>15 kg</b>	<b>12 lt</b>



## SCHEMA DI VENTILAZIONE PER I MINIBAR INCORPORATI

*BUILT IN MINIBAR  
FAN SCHEME*

Per il buon funzionamento del minibar è fondamentale rispettare lo schema di ventilazione.

*To obtain the best performance, it's mandatory to respect the following scheme.*

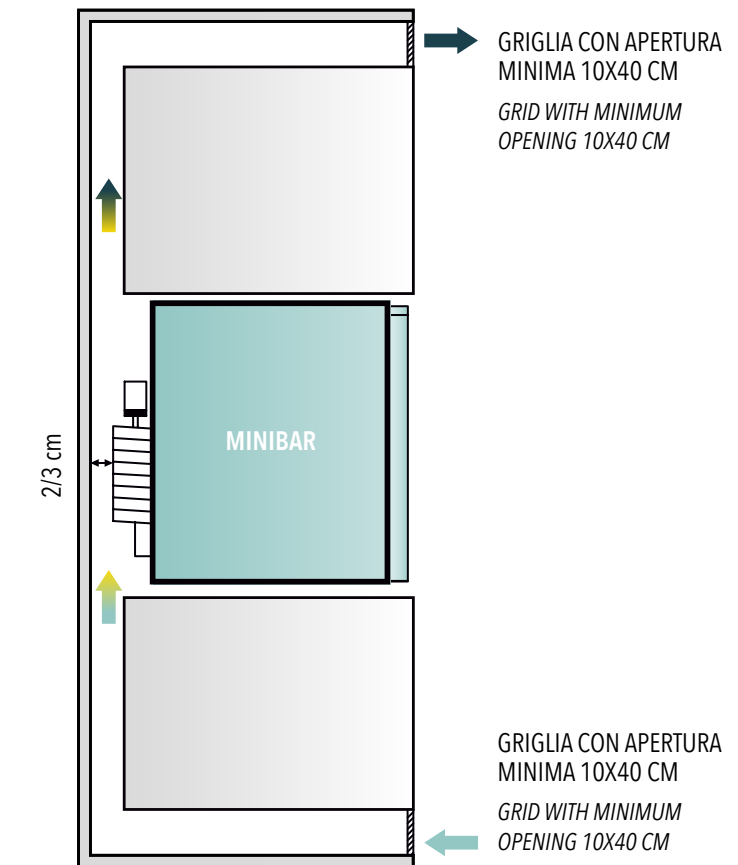

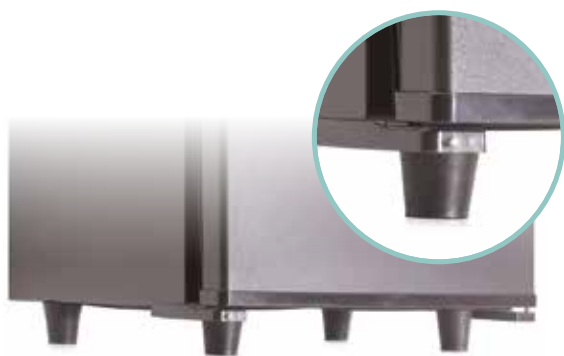

## PIEDINI DI SUPPORTO UNIVERSALI

UNIVERSAL SUPPORT FEET

COD **MBPG**

Modello kit 4 piedini.

*4 feet kit model.*

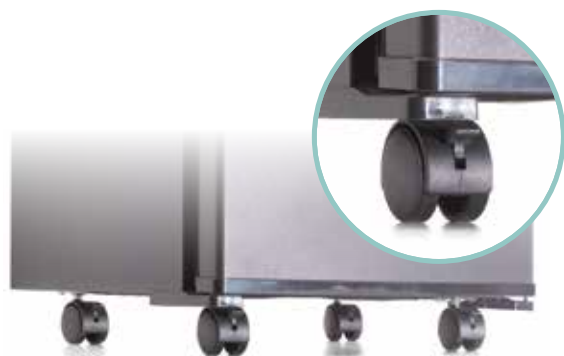

## RUOTE DI SUPPORTO UNIVERSALI

UNIVERSAL SUPPORT WHEELS

COD **MBR4**

Modello kit 4 ruote.

*4 wheels kit model.*



## KIT PER CHIUSURA A CHIAVE UNIVERSALE

UNIVERSAL KEY LOCK KIT

COD **KITSERRMINIBAR**

Modello kit con doppia chiave.

*Double key kit model.*



## STAFFA DI TRAINO PORTA

DOOR TOWING BRACKET

COD **MB30PS**

Modello kit universale. Per installazione a incasso universale. Incluso con il minibar con porta pannellata.

*Universal kit model for recessed installation. Included with the paneled door minibar.*







# CASSEFORTI

*Hotel safe*

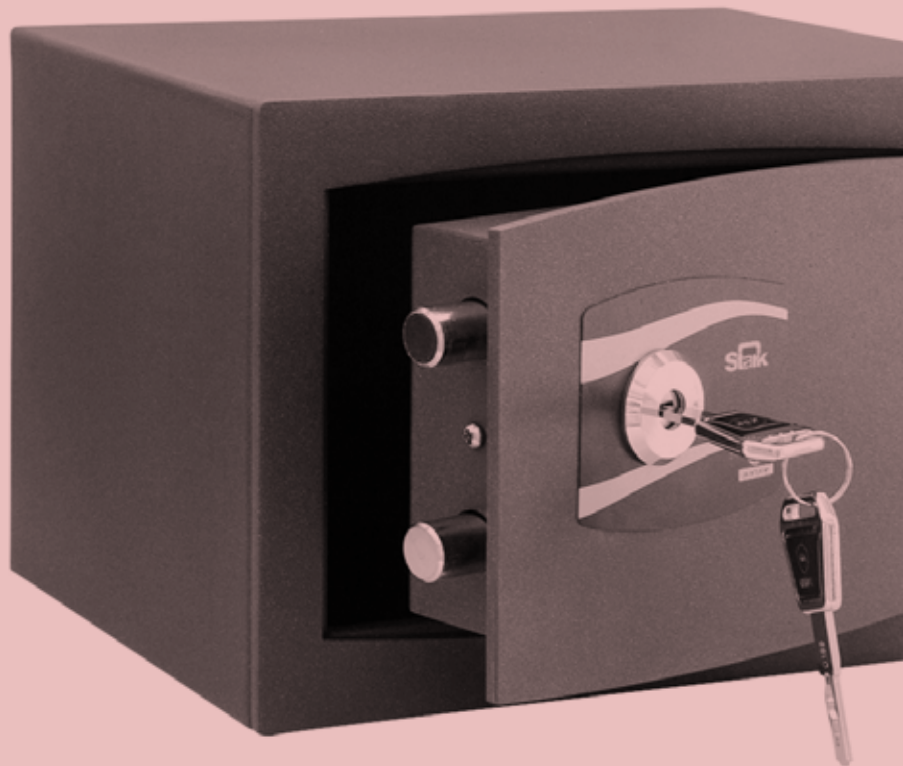

## DATI TECNICI

### TECHNICAL DATA

COD **620U** / COD **620E** / COD **621U**  
COD **622U** / COD **623UTOP**

- \_ Taglio laser del frontale per evitare effrazioni con cacciavite (escluso COD 623UTOP);
- \_ Apertura automatica della porta (escluso COD 623UTOP);
- \_ È possibile inserire un dispositivo di riconoscimento di apertura/chiusura porta interfacciabile a qualsiasi sistema di controllo accesso o building automation;
- \_ Codice cliente a 4 cifre fisso per limitare errori;
- \_ Storico delle ultimi 100 operazioni visualizzabile attraverso CEU unit e display;
- \_ 6 differenti codici master;
- \_ Alimentazione 4 pile alcaline AA;
- \_ Chiave passpartout meccanica di emergenza.

- \_ Door laser cut to avoid forced entry with screwdriver (except COD 623UTOP);
- \_ Automatic opening of the door (except COD 623UTOP);
- \_ Is possible to insert a closing/opening device to be connected to any access control system or building automation;
- \_ 4 digit customer code to limit errors;
- \_ Audit trail of the last 100 operations readable through CEU device and display;
- \_ 6 different master codes;
- \_ Powered by 4 AA alkaline batteries;
- \_ Mechanical emergency passpartout key.

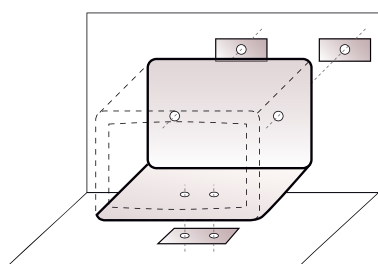

FISSAGGIO: 2 FORI SUL FONDO + 2 FORI SUL RETRO  
(TASSELLI DI FISSAGGIO INCLUSI).  
FIXING: 2 HOLES ON THE BOTTOM + 2 HOLES ON THE BACK  
(FIXING DOWELS INCLUDED).

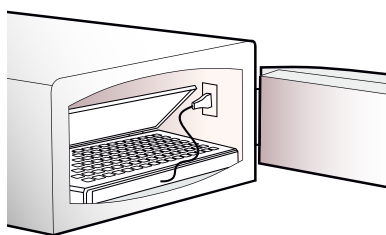

POSSIBILITÀ DI ALIMENTAZIONE PC  
(COD 621U / 622U).  
POSSIBILITY OF PC POWER SUPPLY  
(COD 621U / 622U).

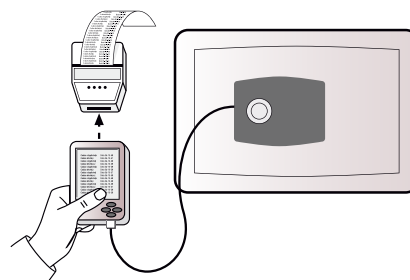

PRESA USB. STORICO DELLE ULTIME 100 OPERAZIONI,  
VISUALIZZABILE ATTRAVERSO CEU UNIT E DISPLAY.  
USB PLUG. AUDIT TRAIL OF THE LAST 100 OPERATIONS  
READABLE THROUGH CEU DEVICE AND DISPLAY.

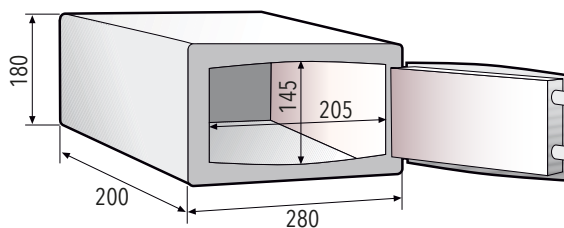

<b>MISURE ESTERNE</b>	l 28 x p 20 x h 18 cm
<b>MISURE INTERNE</b>	l 27,7 x p 14,5 x h 16,9 cm
<b>MISURE PORTA</b>	l 20,5 x h 14,5 cm

## CASSAFORTE PER CAMERA DA 6 LITRI

### 6 LITERS SAFE FOR ROOM

COD **620U**

 peso netto /  
net weight  
**6 kg**

 peso lordo /  
gross weight  
**6,2 kg**

 capacità /  
capacity  
**6 lt**

Cassaforte con tastierino e serratura digitale motorizzata. Luce interna a LED. Display a LED rossi. Apertura automatica della porta. Colore nero opaco e tappetino interno.

Safe with a keypad and motorized digital lock. Internal LED light. Red LED lighted display. Automatic opening of the door. Matte black color and inner mat.



**MISURE ESTERNE** | 135 x p 25 x h 26 cm

## CASSAFORTE PER CAMERA DA 18 LITRI

18 LITERS  
SAFE FOR ROOM

COD **620E**



peso / weight  
**9,5 kg**



capacità / capacity  
**18 lt**

Cassaforte con tastierino e serratura digitale motorizzata. Luce interna a LED. Display a LED rossi. Apertura automatica della porta. Colore nero opaco e tappetino interno.

Safe with keypad and motorized digital lock. Internal LED light. Red LED lighted display. Automatic opening of the door. Matte black color and inner mat.

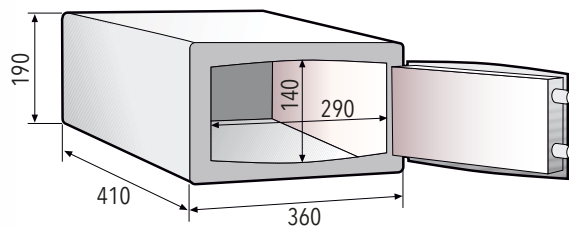

<b>MISURE ESTERNE</b>	136 x p 41 x h 19 cm
<b>MISURE INTERNE</b>	135,5 x p 35,5 x h 17 cm
<b>MISURE PORTA</b>	129 x h 14 cm

## CASSAFORTE PER CAMERA DA 19 LITRI

19 LITERS SAFE FOR ROOM

COD **621U**



peso netto /  
net weight  
**10,2 kg**



peso lordo /  
gross weight  
**10,7 kg**



capacità /  
capacity  
**19 lt**

Cassaforte con tastierino e serratura digitale motorizzata. Luce interna a LED. Display a LED rossi. Apertura automatica della porta. Colore nero opaco e tappetino interno. Adatta a contenere PC.

Safe with keypad and motorized digital lock. Internal LED light. Red LED lighted display. Automatic opening of the door. Matte black color and inner mat. Suitable for containing a pc.



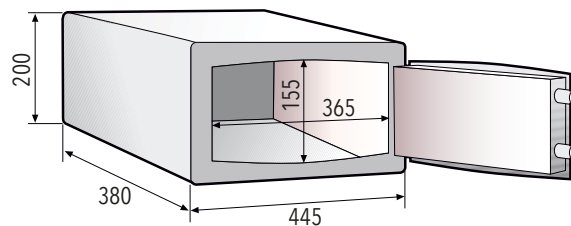

<b>MISURE ESTERNE</b>	l 44,5 x p 38 x h 20 cm
<b>MISURE INTERNE</b>	l 44 x p 32,5 x h 18 cm
<b>MISURE PORTA</b>	l 36,5 x h 15,5 cm

## CASSAFORTE PER CAMERA DA 24,5 LITRI

24,5 LITERS SAFE FOR ROOM

COD **622U**

**Kg** peso netto /  
net weight  
**11,8 kg**

**Kg** peso lordo /  
gross weight  
**12,3 kg**

**capacità /  
capacity**  
**24,5 lt**

Cassaforte con tastierino e serratura digitale motorizzata. Luce interna a LED. Display a LED rossi. Apertura automatica della porta. Colore nero opaco e tappetino interno. Adatta a contenere PC da 17".

*Safe with keypad and motorized digital lock. Internal LED light. Red LED lighted display. Automatic opening of the door. Matte black color and inner mat. Suitable for containing a 17" PC.*



<b>MISURE ESTERNE</b>	l 40 x p 35 x h 13 cm
<b>MISURE INTERNE</b>	l 34,5 x p 34 x h 7 cm

## CASSAFORTE PER CAMERA AD APERTURA DALL'ALTO

SAFE FOR ROOM WITH TOP OPENING

COD **623UTOP**

**Kg** peso / weight  
**11 kg**

**capacità / capacity**  
**8,2 lt**

Cassaforte con tastierino e serratura digitale motorizzata ad apertura dall'alto. Luce interna a LED. Display a LED rossi. Apertura automatica della porta. Colore nero opaco e tappetino interno. Adatta a contenere PC da 17". 2 catenacci.

*Safe with keypad and motorized digital lock with top opening. Internal LED light. Red LED lighted display. Automatic opening of the door. Matte black color and inner mat. Suitable for containing a 17" PC. 2 bolts.*

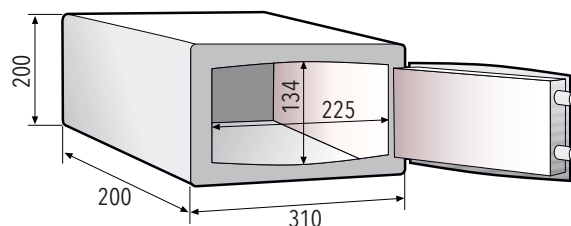

<b>MISURE ESTERNE</b>	l 31 x p 20 x h 20 cm
<b>MISURE PORTA</b>	l 22,5 x h 13,4 cm

## CASSAFORTE PER CAMERA DA 7 LITRI

7 LITERS  
SAFE FOR ROOM

COD **649KNNEW**

peso / weight **6,5 kg** capacità / capacity **7 lt**

Cassaforte a chiave. Taglio laser. Serratura meccanica a cilindro di alta sicurezza. Cilindro masterizzato con chiave cliente e chiave passepartout direzionale. Spessore corpo 1 mm, spessore porta 3 mm. Adatta a contenere PC da 17".

Key safe. Laser cut. High security cylinder mechanical lock. Masterized cylinder with guest key and executive master key. Body thickness 1 mm, door thickness 3 mm. Suitable for containing a 17" PC.

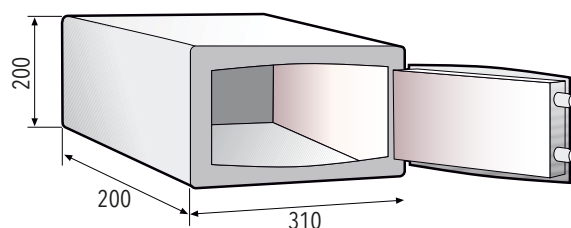

<b>MISURE ESTERNE</b>	l 31 x p 20 x h 20 cm
<b>MISURE INTERNE</b>	l 30,5 x p 14 x h 19,5 cm

## CASSAFORTE PER CAMERA DA 7,5 LITRI

7,5 LITERS  
SAFE FOR ROOM

COD **EA20H23**

peso / weight **7,5 kg** capacità / capacity **7,5 lt**

Cassaforte con tastierino e serratura elettromagnetica. Codice utente da 3 a 8 cifre. Alimentazione con 4 pile stilo da 1,5 V (tipo AA LR6). Colore grigio-nero e tappetino interno. Fornita con 4 tasselli e chiave passpartout meccanica di emergenza.

Safe for room with keypad and electromagnetic lock. Customer code from 3 to 8 digits. Powering through 4 batteries 1,5 V (size AA LR6). Grey-black color and internal carpet. Supplied with 4 mounting bolts and mechanical emergency passpartout key.







<b>MISURE ESTERNE</b>	l 25 x p 15 x h 25 cm
<b>MISURE INTERNE</b>	l 24 x p 10 x h 18,5 cm

## CASSAFORTE PER RECEPTION

SAFE FOR  
RECEPTION

COD **680AR**

 peso / weight  
**6 kg**

 capacità / capacity  
**4,5 lt**

Cassaforte con combinazione digitale con chiusura motorizzata e apertura ritardata. Spessore porta e corpo 3 mm. Tastiera alfanumerica digitale a combinazione di 6 cifre modificabili dall'utente. Tempo di ritardo programmabile: 1-5-10-20 minuti. Tempo di stand-by 1 minuto. Alimentazione esterna in caso di batteria scarica. Fessura 12x120 mm. 2 catenacci. Colore blu metallizzato.

*Safe with motor driven digital combination with delayed opening. Door and walls thickness 3 mm. Digital alpha-numeric keyboard, six digits combination change able by the user. Programmable opening delay: 1-5-10-20 min. Stand-by time 1 min. External powering when the battery is down. Slot 12x120 mm. 2 bolts. Blue metallized color.*

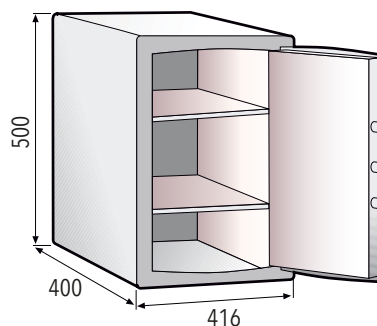

<b>MISURE ESTERNE</b>	l 41,6 x p 40 x h 50 cm
-----------------------	-------------------------

## CASSAFORTE PER RECEPTION DA 70 LITRI

70 LITERS SAFE  
FOR RECEPTION

COD **N3857A**

 peso / weight  
**37 kg**

 capacità / capacity  
**70,0 lt**

Cassaforte con serratura motorizzata digitale. Colore grigio metallizzato. Disponibile anche nella versione con serratura a chiave doppia mappa (cod. N3807). Spessore porta 8 mm. Spessore corpo 3 mm. Due ripiani in dotazione.

*High security with digital motorized lock. Grey metallized color. Available also with double bitted keylock (cod. N3807). Door thickness 8 mm. Body thickness 3 mm. Supplied with two shelves.*



QUESTO ESERCIZIO  
È DOTATO DI UNA  
**CASSAFORTE**  
**ANTIRAPINA CON**  
**SERRATURA A TEMPO**  
**NON DISINSERIBILE**

MISURE ESTERNE	l 20 x p 35 x h 57 cm
MISURE INTERNE	l 19,5 x p 30 x h 56,5 cm

## CASSAFORTE PER RECEPTION CON APERTURA RITARDATA

SAFE FOR RECEPTION WITH PROGRAMMABLE OPENING DELAY

COD **670AR**

 peso / weight  
**15 kg**

 capacità / capacity  
**34,15 lt**

Cassaforte antirapina. Con apertura ritardata (programmabile). Fessura con antiripescaggio per deposito contante. Adesivo per dissuadere eventuali rapinatori. 2 catenacci. Colore blu metallizzato.

*Robberies-proof safe. With programmable opening delay. Anti-fish slot for cash excess deposit. Windows label to discourage eventual robbers. 2 bolts. Blue metallized color.*





<b>MISURE ESTERNE</b>	l 51 x p 45 x h 80 cm
<b>MISURE INTERNE</b>	l 38,5 x p 26,5 x h 67,5 cm

COD **C390**

<b>MISURE ESTERNE</b>	l 51 x p 52 x h 100 cm
<b>MISURE INTERNE</b>	l 38,5 x p 33,5 x h 87,5 cm

COD **C391**

## CASSAFORTE CERTIFICATA EN1143/1° LIVELLO

SAFE CERTIFICATE EN1143/1°

**Kg** peso / weight  
**240 kg** COD **C390**  
**290 kg** COD **C391**

**capacità / capacity**  
**69 lt** COD **C390**  
**113 lt** COD **C391**

Colore Ral 7031. Serratura certificata EN1300/2° livello a valore assicurabile, a chiave doppia mappa ISN11B e a combinazione numerica a 3 cifre CF13. Serratura certificata A2P a valore assicurabile. Pareti interne ed esterne di acciaio Martin Siemens. Corazzatura interna multistrato. Corazza al manganese a protezione delle serrature. Ancoraggio battente-telaio realizzato mediante chiavistelli cilindrici mobili e fissi sul lato cardine. 3 ripiani interni spostabili su cremagliera. Predisposizione per ancoraggio a pavimento e/o parete (1+1 fori).

*Ral 7031 colour. Lock certified according to the EN1300 norm/2nd level assurance value. ISN11B Double bitted lock and 3-dials CF13 numeric combination lock. Assurance value A2P certified lock. Martin Siemens steel for internal and external walls. Multicoated internal armor. Manganese armor to protect the locks. Flaps-structure anchoring made through moving cylindrical bolts and fixed bolts on the. 3 internal removable shelves over the rack. Predisposition for wall and/or floor (1+1 holes) anchoring.*





<b>MISURE ESTERNE</b>	l 10 x p 3,5 x h 12 cm
<b>MISURE INTERNE</b>	l 6 x p 2,5 x h 9 cm

## KEYBOX PER ARCHIVIARE CHIAVI

KEYBOX FOR STORAGE KEYS

COD **KEYBOX**

 peso / weight  
**0,5 kg**

Ideale per custodire in sicurezza oggetti e chiavi. Può essere posizionato all'esterno o all'interno di hotel, abitazioni e uffici. Archiviazione sicura di più chiavi. Combinazione a 4 cifre. 10.000 combinazioni programmabili. Kit di montaggio incluso. Lega di zinco ad alta resistenza e acciaio solido.

*Ideal to guard safely objects and keys. It can be placed outside or inside hotels, homes and offices. Secure storage of more keys. 4 digits combination. 10.000 programmable combinations. Included mounting kit. High strenght zinc alloy and solid steel.*





# SERRATURE

*Locks*





N° 5 CHIAVI ELETTRONICHE RF INCLUSE  
(ANCHE PER IL C-LOCK)  
N° 5 RF ELECTRONIC KEYS INCLUDED  
(ALSO FOR C-LOCK)

**MISURE ESTERNE**

17 x p 1,6 x h 14 cm

## SISTEMA DI ACCESSO PORTA CON TASTIERINO

DOOR ACCESS SYSTEM  
WITH KEYPAD

**COD D-LOCK**



peso netto /  
net weight  
**130 g**



peso lordo /  
gross weight  
**230 g**

Per gestire in maniera semplice e veloce gli accessi nella propria struttura ricettiva. I viaggiatori possono arrivare a ogni ora, senza limiti di check-in, liberando così il responsabile dalla presenza in loco. Il sistema funziona in 3 modalità: password, card/RF o con la combinazione di entrambi. Supporta fino a 3.000 carte utenti. Plastica ABS di alta qualità. Pannello touch screen. Tastiera impermeabile. Programmazione completa da tastiera. Cifre retroilluminate. Possibilità di utilizzare Card o RFID uguale a quella del C-LOCK.

*To manage access in a simple and fast way in your accommodation facility. Travelers are free to arrive at any time, without limit of check-in and thus freeing from the presence on site. The system works in 3 modes: password, Card/RF or with the combination of both. It supports up to 3,000 user cards. High quality plastic ABS. Touch screen panel. Waterproof keyboard. Full programming from keyboard. Figures backlit. Possibility to use Card or RFID equal to that of the C-LOCK.*



N° 5 CHIAVI ELETTRONICHE RF INCLUSE  
(ANCHE PER IL D-LOCK)  
N° 5 RF ELECTRONIC KEYS INCLUDED  
(ALSO FOR D-LOCK)

**MISURE ESTERNE**

16,4 x p 1,5 x h 12,8 cm

## SISTEMA DI ACCESSO PER ARMADIETTI CON TASTIERINO

CABINET ACCESS SYSTEM  
WITH KEYPAD

**COD C-LOCK**



peso netto /  
net weight  
**380 g**



peso lordo /  
gross weight  
**440 g**

Serrature a combinazione o Card/RFID di prossimità. Ideali per armadietti di spogliatoi palestre, scuole, hotel, armadietti portasci, armadietti SPA (in legno, metallo o laminato). Funzionano a batteria e hanno un'autonomia di più di 2 anni. Facile montaggio. La parte meccanica viene applicata all'interno dell'anta, la tastiera numerica all'esterno. Possibilità di utilizzare Card o RFID uguale a quella del D-LOCK.

*Lockers with combination or proximity RFID card. Ideal for cabinet rooms of gyms, schools, hotels, ski cabinets, SPA cabinets (wood, metal or laminate). The electronic lockers for cabinets run on battery and have an autonomy of more than 2 years. The mechanical part is applied inside the door, while the numerical keyboard is applied outside. Possibility to use Card or RFID equal to that of the D-LOCK.*



- SILVER - SERRATURA A SX: COD **HTL1801SL**
- SILVER - SERRATURA A DX: COD **HTL1801SR**
- ORO - SERRATURA A SX: COD **HTL1801GL**
- ORO - SERRATURA A DX: COD **HTL1801GR**

## SERRATURA PER CAMERA, FINITURA METALLO CON RFID

LOCK FOR ROOM, METAL FINISH WITH RFID

Serratura di design per porta di camera d'albergo, con scrocco e catenaccio in acciaio inox. Sistema stand-alone che non necessita di cablaggi. Apertura con RFID card, sblocco di emergenza con card o chiave. Disponibile in colore silver e oro. Alimentata da 4 batterie AAA da 1,5 V, con durata media di 15.000 cicli di apertura e allarme low-power. Adatta per porte dai 30 ai 65 mm di spessore, consigliata per l'installazione in porte in legno. Integrabile con software di gestione e altri accessori per la gestione della porta. Per maggiori informazioni consultare il catalogo specifico delle serrature.

*Design lock for hotel room door, with stainless steel latch and deadbolt. Autonomous system that does not require wiring. Opening with RFID card, emergency unlocking with card or key. Available in silver and gold color. Powered by 4x 1.5V AAA batteries, with an average life of 15,000 opening cycles and low-power alarm. Suitable for doors from 30 to 65 mm thick, recommended for installation in wooden doors. Can be integrated with management software and other accessories for door management. For further information, consult the specific lock catalogue.*

<b>MISURE</b>	17,8 x p 1,8 x h 28,8 cm
---------------	--------------------------



- SILVER - SERRATURA A SX: COD **HTL2801SL**
- SILVER - SERRATURA A DX: COD **HTL2801SR**
- ORO - SERRATURA A SX: COD **HTL2801GL**
- ORO - SERRATURA A DX: COD **HTL2801GR**

## SERRATURA MINIMAL PER CAMERA, FINITURA METALLO CON RFID

LOCK FOR ROOM MINIMAL, METAL FINISH WITH RFID

Serratura dal design elegante e minimale per porta di camera d'albergo, composta sul lato esterno da maniglia e sensore distinti, con scrocco e catenaccio in acciaio inox. Sistema stand-alone che non necessita di cablaggi. Apertura con RFID card, sblocco di emergenza con card o chiave. Disponibile in colore silver e oro. Alimentata da 4 batterie AAA da 1,5 V, con durata media di 15.000 cicli di apertura e allarme low-power. Adatta per porte dai 40 ai 65 mm di spessore, consigliata per l'installazione in porte in legno. Integrabile con software di gestione e altri accessori per la gestione della porta. Per maggiori informazioni consultare il catalogo specifico delle serrature.

*Lock with an elegant and minimal design for hotel room doors, composed on the external side of a separate handle and sensor, with stainless steel latch and deadbolt. Stand-alone system that does not require wiring. Opening with RFID card, emergency release with card or key. Available in silver and gold color. Powered by 4x 1.5 V AAA batteries, with an average life of 15,000 opening cycles and low-power alarm. Suitable for doors from 40 to 65 mm thick, recommended for installation in wooden doors. Can be integrated with management software and other accessories for door management. For further information, consult the specific lock catalogue.*

<b>MISURE</b>	16,5 x h 22,7 cm
---------------	------------------





# ASCIUGACAPELLI

*Hair dryers*



## ASCIUGACAPELLI DA PARETE REGOLABILE COMPATTO

ADJUSTABLE COMPACT HAIR DRYER WITH WALL SUPPORT

COD **HD21**

Asciugacapelli con supporto da parete compatto. Regolatore di potenza e flusso dell'aria. Interruttore generale. **Tasto di sicurezza per hotel.** Potenza 1200 W. Alimentazione/Tensione 230-240 V, 50-60 Hz. Sistema di autoprotezione contro il surriscaldamento. Bassa rumorosità di funzionamento. Plastica autoestinguente. Distanza tra i fori di fissaggio 70 mm. Certificazioni CE/ROHS.

*Hair dryers with compact wall support. Power and air flow regulator. General switch. **Safety button for hotel use.** Power 1200 W. Power supply/Voltage 230-240 V, 50-60 Hz. Overheating self protection. Low working noise. Self-extinguishing plastic material. Distance between holes 70 mm. Certifications CE/ROHS.*

**MISURE**

19 x p 15,5 x h 21 cm



## ASCIUGACAPELLI DA PARETE REGOLABILE COMPATTO CON PRESA RASOIO INTEGRATA

ADJUSTABLE WALL MOUNTED COMPACT HAIR DRYER WITH INTEGRATED SHAVER SOCKET

COD **HD20N**

Asciugacapelli con supporto da parete. Regolatore di temperatura, potenza e flusso dell'aria. **Tasto di sicurezza per hotel.** Potenza 1300 W. Alimentazione/Tensione 220 V, 50-60 Hz. Velocità dell'aria 17m/s. Temperatura dell'aria 65±15°C. Materiale ABS. Certificazioni CE/ROHS.

*Hair dryers with wall support. Wall support. Temperature, power and air flow reg. Power 1300 W. **Safety button for hotel use.** Power supply/Voltage 230-240 V, 50-60 Hz. Air speed 17 m/s. Air temperature 65±15°C. Material ABSC. Certifications CE/ROHS.*

**MISURE**

118,5 x p 10 x h 22 cm



CON PRESA RASOIO  
WITH SHAVER SOCKET



CON PRESA RASOIO  
WITH SHAVER SOCKET



○ BIANCO - COD **HD22W**  
● NERO - COD **HD22B**

## ASCIUGACAPELLI DA PARETE REGOLABILE COMPATTO CON PRESA RASOIO INTEGRATA

*WALL SUPPORT HAIR DRYER WITH ADJUSTABLE ERGONOMIC DESIGN AND INTEGRATED SHAVER SOCKET*

Asciugacapelli con supporto da parete. Design ergonomico. Finitura in gomma morbida. Regolatore di potenza e flusso dell'aria. **Tasto di sicurezza per hotel.** Potenza 1600 W. Alimentazione/Tensione 220 V, 50-60 Hz. Velocità dell'aria 18 m/s. Temperatura dell'aria 65±15°C. Materiale ABS. Certificazioni CE/ROHS.

*Wall support hair dryer. Ergonomic design. Finish in soft rubber. Temperature, power and air flow reg. **Safety button for hotel use.** Power 1600 W. Power supply/Voltage 220 V, 50-60 Hz. Air speed 18 m/s. Air temperature 65±15°C. Material ABS. Certifications CE/ROHS.*

<b>MISURE</b>	l 14,5 x p 28 x h 26 cm
---------------	-------------------------

## ASCIUGACAPELLI DA CASSETTO CON DOPPIE VELOCITÀ E TEMPERATURA

*DRAWER HAIR DRYER WITH DUAL SPEED AND TEMPERATURE*

COD **HDRAWER**

Asciugacapelli da cassetto con finitura cromata. **Tasto di sicurezza per hotel.** 2 livelli di temperatura e 2 livelli d'intensità dell'aria. Cavo spiralato con estensione massima di 3 metri. Potenza 1800 W. Alimentazione/Tensione: 220-240 V, 50-60 Hz. Certificazioni CE/ROHS.

*Drawer hair dryer with chrome finish. **Safety button for hotel use.** 2 heat settings and 2 air flow settings. Spiral cord to be extended up to 3 mt. Power 1800 W. Power supply/Voltage 220-240 V, 50-60 Hz. Certifications CE/ROHS.*



OPZIONALE: SUPPORTO DA MURO  
OPTIONAL: WALL SUPPORT

<b>MISURE</b>	l 26 x p 10 x h 21 cm
---------------	-----------------------



## MINI-ASCIUGAPELLI COMPATTO

COMPACT  
MINI HAIR DRYER





Mini-asciugacapelli comodo, leggerissimo e potente. Con cavo da 1,5 metri e 2 combinazioni temperatura/velocità. Potenza 1220 W. Disponibile in 4 colorazioni: rosso, verde, azzurro e rosa.

*Mini hair dryer comfortable, lightweight and powerful. With 1.5 metre cable and 2 temperature/speed combinations. Power: 1200 W. Available in 4 colors: red, green, blue and pink.*

### MISURE

19 x p 17 x h 17 cm



-  BLU - COD **SPH1212FB**
-  ROSA - COD **SPH1212FP**
-  ROSSO - COD **SPH1212FR**
-  VERDE - COD **SPH1212FV**

## ASCIUGACAPELLI DA CASSETTO COMPATTO

COMPACT DRAWER  
HAIR DRYER



Asciugacapelli con 3 combinazioni di velocità/temperatura e cavo da 2 metri. In dotazione con un concentratore, è leggerissimo e potente. Il suo design lo rende perfetto per chi preferisce un asciugacapelli meno ingombrante ma allo stesso tempo efficace per ogni tipo di acconciatura. Potenza 1800 W.

*Hair dryer with 3 speed/temperature combinations and 2 metre cable. Supplied with a concentrator, it is lightweight and powerful. Its design makes it perfect for those who prefer a less bulky and more efficient hair dryer. Power 1800 W.*

### MISURE

115 x p 8,5 x h 21 cm



-  VERDE - COD **SPH1818NV**
-  NERO - COD **SPH1818N**



● NERO/ARANCIONE - COD **SPH1820A**

● NERO/ROSSO - COD **SPH1820R**



## ASCIUGACAPELLI DA CASSETTO

*DRAWER HAIR DRYER*

Asciugacapelli con 6 combinazioni temperatura/velocità e cavo da 2 metri. Leggerissimo e potente. Lo strumento perfetto per ogni tipo di acconciatura desiderata. In dotazione con 2 concentratori. Potenza 1800 W.

*Hair dryer with 6 temperature/speed combinations and 2 metre cable. Lightweight and powerful. Supplied with 2 concentrators. Power 1800 W.*

**MISURE**

l 23,5 x p 9 x h 24,5 cm

## ASCIUGACAPELLI DA CASSETTO CON MOTORE AC PER USO PRO

*DRAWER HAIR DRYER WITH  
AC MOTOR FOR PRO USE*

COD **SPH2009AC**

Asciugacapelli con motore AC per uso professionale con 6 combinazioni velocità/temperatura, prestazione elevate ad uso continuo. Cavo da 2 metri. Dotato di 6 combinazioni temperatura/velocità (tra cui anche "colpo di freddo"), fornito con 2 concentratori differenti e un diffusore. Design ergonomico ed elegante, perfetto per ogni tipo di acconciatura ed evento. Potenza 2000 W.

*Hair dryer with AC motor for professional use, high performance for continuous use. 2 metre cable. Features 6 temperature/speed combinations (including "cold blow"), supplied with 2 different concentrators and a diffuser. Ergonomic and elegant design. Power 2000 W.*

**MISURE**

l 24,5 x p 10 x h 26 cm





# ASCIUGAMANI AD ARIA

*Hand dryers*



## ASCIUGAMANI AD ARIA CON FLUSSI AD ALTA VELOCITÀ

HAND DRYER WITH  
HIGH-SPEED AIRFLOWS

COD **AM20N**

Asciugamani elettrico a muro, con vaschetta raccogli-acqua per non bagnare il pavimento. Asciuga in 7 secondi grazie al doppio convogliatore a lame d'aria. Si attiva con fotocellula (nessun contatto diretto con la superficie). Ultra silenzioso: basso livello sonoro < 88 dB. Potenza 2000 W. Velocità di ventilazione 342 km/h. Voltaggio 220 V, 50-60 Hz. Materiale ABS. Staffe in dotazione per un rapido fissaggio. Certificazioni CE/ROHS.

*Wall support electric hand dryer, with a water tank containment avoids unnecessarily wet the floor. Dries hands in 7 seconds thanks to the double conveyor air blades. Activated by photocell (no direct contact with the surface). Silent: low noise level < 88 dB. Power 2000 W. Fan speed 342 km/h. Voltage 220 V, 50-60 Hz. Material ABS. The supports supplied allow an easy and quick installation. CE/RHOS certification.*

**MISURE** | 29,7 x p 16,4 x h 57,4 cm

 peso / weight  
**10 kg**



VASCHETTA  
RACCOGLI-ACQUA  
WATER TANK

## ASCIUGAMANI AD ARIA ENTRY LEVEL

ENTRY-LEVEL HAND DRYER

COD **AM3**

Asciugamani da parete bianco. Supporto da parete. Si attiva tramite fotocellula. Bassa rumorosità < 70dB. Potenza 1800 W. Velocità di ventilazione 60 m/s. Voltaggio 220-240 V, 50-60 Hz. Materiale plastica autoestinguente. Staffe in dotazione per un rapido fissaggio. Classe di isolamento IPX1. Certificazioni CE/ROHS.

*White wall support hand dryer. Wall support included. Switch on through photocell. Low working noise < 70dB . Power 1800 W. Fan speed 60 m/s. Voltage 220-240 V, 50-60 Hz. Self-extinguishing plastic material. Mounting bracket included. Double security insulation IPX1. Certifications CE/ROHS.*

**MISURE** | 24 x p 23 x h 24 cm

 peso / weight  
**2,5 kg**





CONO D'ARIA  
AIR CONE



CONO D'ARIA  
AIR CONE



CONO D'ARIA  
AIR CONE

## ASCIUGAMANI AD ARIA INOX 1200W

HAND DRYER MADE OF  
STAINLESS STEEL 1200W

COD **AM1U**

Asciugamani a parete in finitura cromata. Flusso d'aria ad alta velocità. Asciuga in 10-12 secondi grazie a un cono d'aria. Luce UV antibatterica. Temperatura aria 40°C. Voltaggio 230 V. Potenza 1200 W.

*Wall support hand dryer with a chrome finish. High-speed air flow. Dries in 10-12 seconds thanks to a air cone. Equipped with antibacterial UV light. Air temperature 40°C. Voltage 230V. Power 1200 W.*

**MISURE** | 20,8 x p 16,6 x h 27,8 cm

**kg** peso / weight  
**12 kg**

## ASCIUGAMANI AD ARIA INOX 1800W

HAND DRYER MADE OF  
STAINLESS STEEL 1800W

COD **AM1U1800**

Asciugamani a parete in finitura cromata. Flusso d'aria ad alta velocità. Asciuga in 7-10 secondi grazie a un cono d'aria. Luce UV antibatterica. Temperatura aria 40°C. Voltaggio 230 V. Potenza 1800 W.

*Wall support hand dryer with a chrome finish. High-speed air flow. Dries in 7-10 seconds thanks to a air cone. Equipped with antibacterial UV light. Air temperature 40°C. Voltage 230V. Power 1800 W.*

**MISURE** | 20,8 x p 16,6 x h 27,8 cm

**kg** peso / weight  
**12 kg**

## ASCIUGAMANI AD ARIA INOX

HAND DRYER MADE  
OF STAINLESS STEEL

COD **AM1**

Asciugamani a parete in finitura cromata lucida. Asciuga in 10 secondi grazie a un cono d'aria. Nessun contatto con la superficie grazie alla fotocellula che permette l'accensione. Rumorosità < 88 dB. Potenza 1800 W. Velocità di ventilazione 60 m/s. Voltaggio 220-240 V. Materiale Inox AISI 304. Classe di isolamento IPX1. Certificazioni CE/ROHS.

*Wall support towels with a chrome finish. Dries in 10 seconds thanks to a air cone. No contact with the hand dryer surface thanks to the photocell which allows the ignition. Noise < 88 dB. Power 1800 W. Fan speed 60 m/s. Voltage 220-240 V. Material Inox AISI 304. Insulation class IPX1. Certifications CE/ROHS.*

**MISURE** | 29,8 x p 17 x h 32,2 cm

**kg** peso / weight  
**5 kg**







# ATTREZZATURE COLAZIONE

*Breakfast equipment*



## BOLLITORE ELETTRICO DA 1 LT IN PLASTICA

*ELECTRIC PLASTIC KETTLE  
WITH 1 LT CAPACITY*

COD **B2001P**

Bollitore elettrico in plastica. Capacità 1 lt. Base girevole a 360°. Arresto automatico (protezione surriscaldamento)/ manuale. Coperchio di sicurezza. Alimentazione 220-240V, 50-60 Hz. Potenza 1850-2200W. Certificazioni CE, RoHS. Compatibile con vassoi WTRAYCF e WTRAY.

*Electric plastic kettle. Capacity 1 lt. 360° rotating base. Automatic (overheat protection) / manual shut-off. Security lid. Power supply 220-240V, 50-60Hz. Power 1850-2200W. Certifications CE, RoHS. Compatible with WTRAYCF and WTRAY trays.*

**MISURE**

l 16,5 x p 22 x h 17 cm



pezzi / pieces  
**1**



## BOLLITORE ELETTRICO DA 1 LT IN ACCIAIO

*STEEL ELECTRIC KETTLE 1 LT*

COD **B2002AS**

Bollitore in acciaio inox. Capacità 1 lt. Con base girevole a 360°. Arresto automatico (protezione surriscaldamento)/ manuale. Coperchio di sicurezza. Alimentazione 220V, 50-60 Hz. Potenza 1350W. Lunghezza cavo: 55 cm. Base ø 16 cm. Certificazioni CE, RoHs, LVD, EMC, LFGB. Compatibile con vassoi WTRAYCF e WTRAY.

*Stainless steel kettle. Capacity 1 lt. With 360° rotating base. Automatic/manual shut-off (overheat protection). Safety lid. Power supply 220V, 50-60 Hz. Power 1350W. Cord length 55 cm. Base ø 16 cm. Certifications CE, RoHs, LVD, EMC, LFGB. Compatible with WTRAYCF and WTRAY trays.*

**MISURE**

l 17 x p 22 x h 21 cm



pezzi / pieces  
**1**





## BOLLITORE ELETTRICO DA 0.6 LT IN ACCIAIO

STEEL ELECTRIC  
KETTLE 0.6 LT

COD **B2006**

Bollitore nero in acciaio inox. Capacità 0,6 lt. Potenza 600W 220V 50Hz. Compatibile con vassoi WTRAYCF e WTRAY.

*Black stainless steel kettle. Capacity 0.6 lt. Power 600W 220V 50Hz. Compatible with WTRAYCF and WTRAY trays.*

**MISURE**

l 11 x h 15,8 cm



pezzi / pieces  
**1**

## TAZZA IN CERAMICA

CERAMIC MUG

COD **MUG**

Tazza in porcellana new bone. Colore nero. Certificata per contatto con alimenti.

*New bone porcelain mug. Color black. Certified for food contact.*



**MISURE**

l 11,5 x p 8 x h 8 cm



pezzi / pieces  
**48**



## VASSOIO DI CORTESIA IN ABS

WELCOME TRAY  
IN ABS

COD **WTRAYCF**

Vassoio cortesia in ABS per macchina del caffè KOFFE e bollitore. Colore nero. Scomparti per bustine e capsule caffè. Attacco integrato per bollitore B2002AS e B2001P. Con piedini antiscivolo.

*Welcome tray in ABS for KOFFE coffee machine and kettle. Black color. Compartments for coffee bags and capsules. Integrated attachment for B2002AS and B2001P kettle. With non-slip feet.*

**MISURE** | 42 x p 31,5 x h 2,5 cm



## VASSOIO DI CORTESIA IN ABS

WELCOME TRAY  
IN ABS

COD **WTRAY**

Vassoio di cortesia in ABS con griglia in acciaio Inox removibile. Colore nero. Per tazze, scomparti per bustine, attacco integrato per bollitori elettrici (B2001P / B2002AS).

*Welcome tray in ABS with stainless steel removable grid. Black color. For cups, compartments for tea and sugar bags, integrated socket for electric kettles (B2001P / B2002AS). Non-slip feet.*

**MISURE** | 44,3 x p 22,7 x h 3,6 cm

 peso / weight  
**0,65 kg**





- BIANCO - COD **KOFFE-B**
- NERO - COD **KOFFE-N**
- GRIGIO - COD **KOFFE-G**
- ROSSO - COD **KOFFE-R**
- CREMA - COD **KOFFE-C**

## MACCHINA PER CAFFÈ A CIALDE E CAPSULE

COFFEE MACHINE FOR  
PODS AND CAPSULES

Macchina per caffè compatta. Compatibile con capsule Nespresso e Dolce Gusto. Compatibile con cialde. Memorizza la lunghezza preferita. Inclusa una scatola di capsule Nespresso + una scatola di capsule Dolce Gusto + una scatola di cialde. Disponibile in 5 colori.

*Compact coffee machine. Compatible with Nespresso and Dolce Gusto capsules. Compatible with pods. Stores your preferred length. Includes a box of Nespresso capsules + a box of Dolce Gusto capsules + a box of pods. Available in 5 colors.*

**MISURE** 122 x p 16,5 x h 17 cm

**kg** peso / weight  
**2,5 kg**

## ADATTATORI PER MACCHINA DEL CAFFÈ

ADAPTERS FOR  
COFFEE MACHINE

### COD **SADCP31**

Compatibile con caffè in polvere.  
*Compatible with coffee powder.*

### COD **SADCI31**

Compatibile con sistema Caffitaly.  
*Compatible with Caffitaly system.*

### COD **SADLM31**

Compatibile con sistema Lavazza a modo mio.  
*Compatible with Lavazza a modo mio system.*

### COD **SADCD31**

compatibile con sistema Dolce Gusto.  
*Compatible with Dolce Gusto system.*

### COD **SADCN31**

Compatibile con sistema Nespresso.  
*Compatible with Nespresso system.*

### COD **SADCC31**

compatibile con cialde.  
*Compatible with pods.*

**MISURE** h 6 x p 10 x l 7 cm

**kg** peso / weight  
**180 g**





# PORTA VALIGIE

*Luggage rack*



## REGGIVALIGIA PIEGHEVOLE CON CINGHIE

FOLDING LUGGAGE STAND  
WITH STRAPS

COD. **.RVCROMO**

Reggivaligia in acciaio con finitura cromata lucida. Con cinghie nere in PVC. Diametro tubolare 25 mm. Spessore tubolare 0.8 mm. Portata max 60 kg.

*Steel luggage rack with polished chrome finish. PVC black belts. Tubular diam. 25 mm. Tubular thickness 0.8 mm. Maximum capacity 60 kg.*

**MISURE**

h 53,5 x p 41 x l 68 cm



pezzi / pieces

**2**



## REGGIVALIGIA PIEGHEVOLE CON CINGHIE

FOLDING LUGGAGE STAND  
WITH STRAPS

COD. **.RVOTONE**

Reggivaligia in acciaio con finitura ottonata lucida. Con cinghie nere in PVC. Diametro tubolare 25 mm. Spessore tubolare 0.8 mm. Portata max 60 kg. Senza sponda.

*Steel luggage rack with polished brass finish. PVC black belts. Tubular diam. 25 mm. Tubular thickness 0.8 mm. Maximum capacity 60 kg. Flat top.*

**MISURE**

h 53,5 x p 41 x l 68 cm



pezzi / pieces

**2**







## REGGIVALIGIA CON SPONDINA PIEGHEVOLE CON CINGHIE

LUGGAGE RACK WITH FOLDABLE  
SIDE RAILS AND STRAPS

COD **.RVCROMO/S**

Reggivaligia in acciaio con finitura cromata lucida. Con cinghie nere in PVC. Diametro tubolare 25 mm. Spessore tubolare 0.8 mm. Portata max 60 kg. Con sponda.

*Steel luggage rack with polished chrome finish. PVC black belts. Tubular diam. 25 mm. Tubular thickness 0.8 mm. Maximum capacity 60 kg. High back.*

**MISURE**

h 72,5 x p 43 x l 67 cm



pezzi / pieces  
**2**



## REGGIVALIGIA CON SPONDINA PIEGHEVOLE CON CINGHIE

LUGGAGE RACK WITH FOLDABLE  
SIDE RAILS AND STRAPS

COD **.RV OTTONE/S**

Reggivaligia in acciaio con finitura ottonata lucida. Con cinghie nere in PVC. Diametro tubolare 25 mm. Spessore tubolare 0.8 mm. Portata max 60 kg. Con sponda.

*Steel luggage rack with polished brass finish. PVC black belts. Tubular diam. 25 mm. Tubular thickness 0.8 mm. Maximum capacity 60 kg. High back.*

**MISURE**

h 72,5 x p 43 x l 67 cm



pezzi / pieces  
**2**



## CARRELLO PORTA VALIGIE CON APPENDIABITI E RUOTE

LUGGAGE CARTS WITH HANGERS  
AND WHEELS

COD **CART-S**

Carrello portavaligie con appendiabiti in acciaio inox cromato. Base in metallo rinforzato ricoperta da moquette nera. Bordo paracolpi perimetrale in gomma. Tubolare diametro 0.38 mm. Ruote di diametro 150 mm, 2 piroettanti e 2 fisse. Il carrello viene spedito in kit smontato.

*Luggage trolley with chromed stainless steel coat hanger. Reinforced metal base covered with black carpet. Rubber perimeter bumper edge. Tubular diameter 0.38 mm. Wheels 150 mm diameter 2 swivel and 2 fixed. The cart is shipped in disassembled kit.*

**MISURE** h 187 x p 69,5 x l 113,5 cm



## CARRELLO PORTA VALIGIE CON APPENDIABITI E RUOTE

LUGGAGE CARTS WITH HANGERS  
AND WHEELS

COD **CART-G**

Carrello portavaligie con appendiabiti in acciaio inox ottonato. Base in metallo rinforzato ricoperta da moquette nera. Bordo paracolpi perimetrale in gomma. Tubolare diametro 0.38 mm. Ruote di diametro 150 mm, 2 piroettanti e 2 fisse. Il carrello viene spedito in kit smontato.

*Luggage trolley with brass-plated stainless steel coat hanger. Reinforced metal base covered with black carpet. Rubber perimeter bumper edge. Tubular diameter 0.38 mm. Wheels 150 mm diameter 2 swivel and 2 fixed. The cart is shipped in disassembled kit.*

**MISURE** h 187 x p 69,5 x l 113,5 cm







# ATTREZZATURE DI SERVIZIO

*Service equipment*

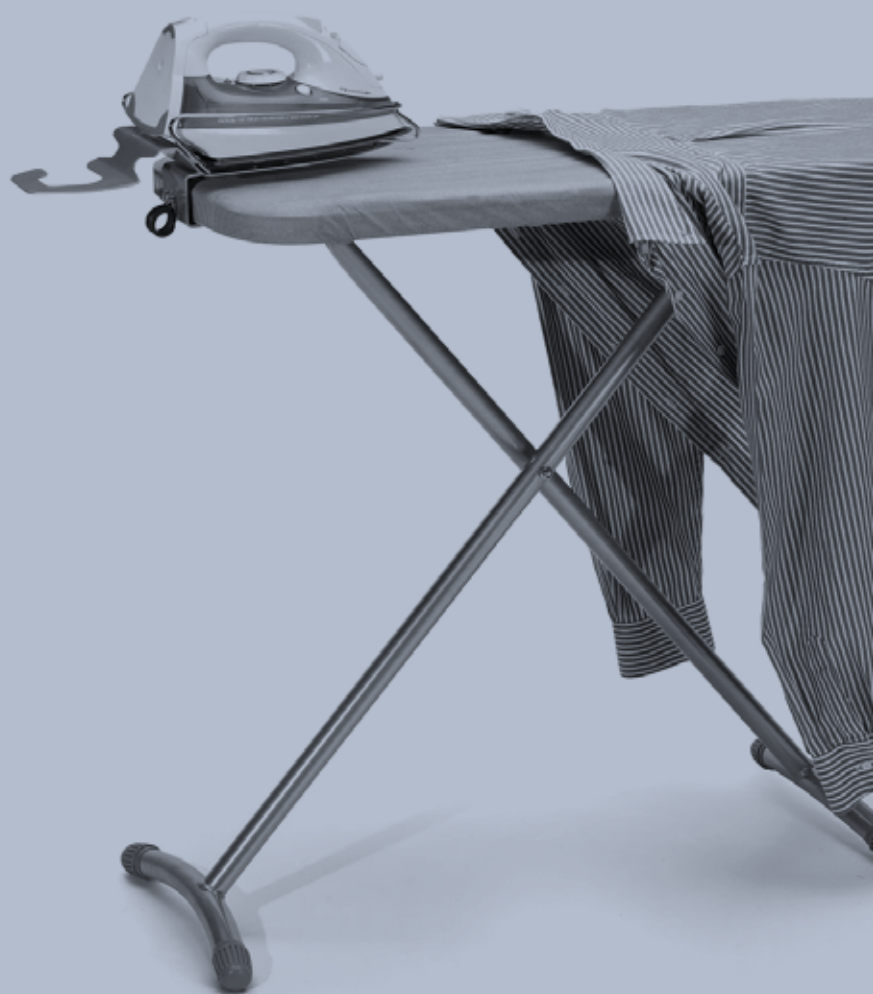

## FERRO DA STIRO A VAPORE

STEAM IRON

COD **ASIRONSP**

Dotato di sensore di movimento con auto-spegnimento di sicurezza. Dopo 30 secondi di inutilizzo sulla piastra e 5 minuti in posizione verticale. Piastra antiaderente. Luce di funzionamento con indicatore di spegnimento. Potenza 220-240 V AC - 1800 Watt. Certificazione CE.

*Equipped with motion sensor and auto-cut off safety. After 30 seconds of inactivity on the plate and 5 minutes in a vertical position. Non-stick soleplate. Operating light with cut-out indicator. Power 220-240 V AC - 1800 Watt. CE certification.*

**MISURE** h 28 x p 12,5 x l 15,5 cm

 peso / weight  
**1 kg**



## FERRO DA STIRO CON CALDAIA

IRON WITH BOILER  
WITH 900 ML TANK

COD **SFSC300**

Ferro da stiro dotato di caldaia con serbatoio da 900 ml. Con manometro e regolatore vapore. Potenza max vapore 35 C°/min. La piastra più grande, in alluminio, e le funzionalità di sicurezza e controllo del vapore, garantiscono una stiratura super efficace per ogni tipologia di vestiario.

*Iron with boiler. Max steam output 35 C°/min. The larger aluminium soleplate and the safety and steam control features provide super effective ironing for all types of clothes. With pressure gauge and steam regulator.*

**MISURE** h 33 x p 34,5 x l 22,5 cm

 peso / weight  
**1 kg**



## COPRIASSE IGNIFUGO

FIREPROOF IRONING  
BOARD COVER

COD **ASCLOTH**

Copriasse ignifugo per asse da stiro.

*Flameretardant ironing board cover.*

**MISURE** h 110 x l 33 cm



## POSTAZIONE COMPLETA DA STIRO CON ASSE PIEGHEVOLE E FERRO DA STIRO

*IRONING CENTRE COMPLETE  
WITH FOLDING IRONING  
BOARD AND IRON*

COD **AS**

Asse con ferro da stiro e alloggiamento, pieghevole e riponibile con gancio salva-spazio composta da:

### 1. ASSE - AS BOARD

Alloggio per ferro da stiro rotante e resistente al calore. Telaio robusto e leggero. Funzione anti-furto per impedire la rimozione del ferro. Copertura asse da stiro alluminizzata imbottita con feltro. Piano in rete metallica traspirante. Verniciatura a polvere grigio metallizzato. 7 livelli di regolazione in altezza fino a 850 mm. Peso AS BOARD imballato 7 kg.

### 2. FERRO - AS IRON

Sensore di movimento con auto-spegnimento di sicurezza dopo 30 secondi di inutilizzo sulla piastra e 5 minuti in posizione verticale. Piastra antiaderente. Luce di funzionamento con indicatore di spegnimento. 220-240 V AC-1800 Watt. Certificazione CE AS IRON.

### 3. AS HOLDER

Sede rotante per ferro da stiro con fermacavo antifurto.

*Ironing board with iron and housing, foldable and stowable with space-saving hook:*

### 1. BOARD - AS BOARD

*Heat resistant, rotating iron holster. Strong and lightweight frame. Anti-thief feature to prevent removal of the iron. Aluminised, felt-padded ironing board cover. Metal mesh board with steam flow. Metallic grey powder coated finish. 7 levels of height adjustment up to 850 mm.*

### 2. IRON - AS IRON

*Motion sensor with auto-cut off safety after 30 seconds of inactivity on the soleplate and 5 minutes in upright position. Non-stick soleplate. Operating light with switch-off indicator. 220-240 V AC-1800 Watt. CE AS IRON certification.*

### 3. AS HOLDER

*Rotating iron holster with anti-thief cable lock.*



SEDE ROTANTE  
PER FERRO DA STIRO  
ROTATING IRON HOLSTER



FERMA CAVO  
ANTIFURTO  
ANTI THIEF CABLE LOCK

MISURE PIANO	h 110 x l 30 cm
MISURE ASSE CHIUSO	h 136 x p 24 x l 34 cm
LUNGHEZZA GANCIO COMPRESO	136 cm
SPESSORE CON FERRO DA STIRO	24 cm
SPESSORE SENZA FERRO DA STIRO	14,5 cm



## CARRELLO PER PULIZIE IN CAMERA CON SINGOLO SACCO REMOVIBILE

CLEANING CART WITH  
SINGLE REMOVABLE BAG

COD **LCART1**

Carrelli per servizio in camera in acciaio verniciato rosso/marrone. Protezione paraurti in gomma. 1 sacco per la biancheria removibile. Venduto smontato (dimensioni pacco l 90 x p 50 x h 23 cm). Ruote di diametro 10 cm.

*Carts for room service in red/brown painted steel. Rubber bumper protector. 1 removable laundry bag. Sold disassembled (package dimensions w 95 x d 50 x h 23 cm). Wheels 10 cm diameter.*

**MISURE**

h 105 x p 46 x l 90 cm



peso / weight  
**24 kg**



## CARRELLO PER PULIZIE IN CAMERA CON DOPPIO SACCO REMOVIBILE

CLEANING CART WITH  
DOUBLE REMOVABLE BAG

COD **LCART2**

Carrelli per servizio in camera in acciaio verniciato rosso/marrone. Protezione paraurti in gomma. 2 sacchi per la biancheria removibili. Venduto smontato (dimensioni pacco l 144 x p 50 x h 22 cm). Ruote di diametro 10 cm.

*Carts for room service in red/brown painted steel. Rubber bumper protector. 2 removable laundry bags. Sold disassembled (package dimensions w 144 x d 50 x h 22 cm). Wheels 10 cm diameter.*

**MISURE**

h 112 x p 46 x l 140 cm



peso / weight  
**29 kg**





## RUOTE XL PER CARRELLO DI SERVIZIO USO ESTERNO

*XL WHEELS FOR OUTDOOR  
SERVICE TROLLEY*

COD **RLCART**



Ruote per carrelli con diametro maggiorato, adatte anche all'uso negli spazi esterni della struttura. Compatibili con i carrelli LCART1 e LCART2. Materiale TPR. Ogni set contiene 2 guide per ruote + 2 ruote (1 fissa e 1 direzionabile). I set vengono venduti in coppia per garantire la possibilità di ricambio di tutte le ruote del carrello (4 in totale).

*Cart wheels with enlarged diameter, also suitable for use in outdoor areas of the facility. Compatible with LCART1 and LCART2 carts. Material TPR. Each set contains 2 guide wheels + 2 wheels (1 fixed and 1 directional). The sets are sold in pairs to provide spare wheels for all trolley wheels (4 in total).*

**MISURE**

h 18,5 cm / ø 14 cm



pezzi / pieces  
**2**

## LUCIDA SCARPE ELETTRICO AUTOMATICO CON SPAZZOLE INTERCAMBIABILI

*AUTOMATIC ELECTRIC  
SHOE SHINER WITH  
CHANGEABLE BRUSHES*

COD **HLS4**



COD **HLS4CREAM**

RICARICA CREMA NEUTRA DA 180 ML  
NEUTRAL CREAM REFILL, 180 ML

Lucida scarpe elettrico con attivazione/spengimento automatici a sensore. 2 spazzole intercambiabili lavabili (1 spazzola per scarpe chiare, 1 spazzola per scarpe scure, entrambe con funzione pulitura e lucidatura). Contenitore cera ricaricabile, capacità 150 ml. Alimentazione 230 V - 50 Hz. Potenza 100 W. Velocità di rotazione delle spazzole 1200 rpm. Colore acciaio e grigio scuro. In dotazione un flacone di crema neutra.

*Electric shoe polisher with automatic switch on/switch off by sensor. 2 changeable and washable brushes (1 brush for clear shoes, 1 brush for dark shoes, both of them for cleaning and polishing). Rechargeable polish container, capacity 150 ml. Powering 230V - 50 Hz. Power 100 W. Brush speed rotation 1200 rpm. Steel and dark grey colors. Supplied with a neutral cream bottle.*

**MISURE**

h 33 x p 20 x l 37 cm



peso / weight  
**6,2 kg**





# PATTUMIERE

*Dustbins*



## CESTINO IN PLASTICA

PLASTIC DUSTBIN

COD **BINW10L**

Pattumiera da camera in plastica bianca.

*White plastic bedroom dustbin.*

**MISURE**

h 30,5 cm / ø 23,5 cm



pezzi / pieces  
**1**



capacità / capacity  
**10 Lt**



## CESTINO IN ACCIAIO CON BLOCCA SACCHETTO IN INOX

STEEL DUSTBIN WITH  
STAINLESS STEEL BAG LOCK

COD **BINB-10**

Pattumiera da camera in acciaio verniciato nero con blocco sacchetto. In acciaio Inox.

*Black painted dustbin steel bedroom with bag lock. In stainless steel.*

**MISURE**

h 25 cm / ø 22,5 cm



pezzi / pieces  
**1**



capacità / capacity  
**10 Lt**



## CESTINO IN ACCIAIO CON TRE SCOMPARTI IN PLASTICA

STEEL WASTE BIN WITH THREE  
PLASTIC COMPARTMENTS

COD **BIN10**

Pattumiera per la raccolta differenziata in acciaio Inox con 3 scomparti in plastica colorata. Disponibile in nero, blu e marrone.

*Stainless steel recycling waste bin with 3 colored plastic compartments. Model black, blue and brown colors.*

**MISURE**

h 32,6 cm / ø 24,3 cm



pezzi / pieces  
**1**



capacità / capacity  
**10 Lt**



RACCOLTA DIFFERENZIATA  
RECYCLING WASTE



## PATTUMIERA A PEDALE IN ACCIAIO INOX DA 3 LT

STAINLESS STEEL PEDAL  
BIN 3 LT

COD **IRON1INOX**

Pattumiera da bagno a pedale con funzione di chiusura rallentata. Struttura in 410 acciaio INOX. Rivestimento interno in plastica. Peso 0,6 kg.

*Pedal bin with slow down silent function. Frame made of 410 stainless steel. Plastic liner. Weight: 0.6 kg*

**MISURE** h 25,7 cm / Ø 16,8 cm



pezzi / pieces  
**6**



capacità / capacity  
**3 Lt**



## PATTUMIERA A PEDALE IN ACCIAIO INOX DA 5 LT

STAINLESS STEEL PEDAL  
BIN 5 LT

COD **IRON2INOX**

Pattumiera da bagno a pedale con funzione di chiusura rallentata. Struttura in 410 acciaio INOX. Rivestimento interno in plastica. Peso 0,75 kg.

*Pedal bin with slow down silent function. Frame made of 410 stainless steel. Plastic liner. Weight: 0.75 kg*

**MISURE** h 27,7 cm / Ø 20,5 cm



pezzi / pieces  
**6**



capacità / capacity  
**5 Lt**



## PATTUMIERA A PEDALE IN ACCIAIO INOX 12 LT

STAINLESS STEEL PEDAL  
BIN 12 LT

COD **IRON3INOX**

Pattumiera da bagno a pedale con funzione di chiusura rallentata. Struttura in 410 acciaio INOX. Rivestimento interno in plastica. Peso 1,5 kg.

*Pedal bin with slow down silent function. Frame made of 410 stainless steel. Plastic liner. Weight: 1.5 kg*

**MISURE** h 39,5 cm / Ø 25 cm



pezzi / pieces  
**4**



capacità / capacity  
**12 Lt**

## PATTUMIERA A PEDALE IN ACCIAIO DA 3 LT

PEDAL STEEL  
DUSTBIN 3 LT

COD **SP158003**

Pattumiera da bagno a base tonda a pedale in acciaio. Dotata di cestello interno removibile. Finitura a specchio.

*Steel dustbin with pedal. With 3 liter inner bucket. Features removable inner bucket. Mirror finish.*

**MISURE** h 24 cm / Ø 16 cm



pezzi / pieces  
**1**



capacità / capacity  
**3 Lt**



## PATTUMIERA A PEDALE IN ACCIAIO DA 5 LT

PEDAL STEEL  
DUSTBIN 5 LT

COD **SP158005**

Pattumiera da bagno a base tonda a pedale in acciaio. Dotata di cestello interno removibile. Finitura a specchio.

*Steel dustbin with pedal. Features removable inner bucket. Mirror finish.*

**MISURE** h 26 cm / Ø 20 cm



pezzi / pieces  
**1**



capacità / capacity  
**5 Lt**



## PATTUMIERA A PEDALE IN ACCIAIO DA 12 LT

ROUND PEDAL STEEL  
DUSTBIN 12 LT

COD **SP1580012**

Pattumiera da bagno a base tonda a pedale in acciaio. Dotata di cestello interno removibile. Finitura a specchio.

*Steel dustbin with pedal. Features removable inner bucket. Mirror finish.*

**MISURE** h 38 cm / Ø 25 cm



pezzi / pieces  
**1**



capacità / capacity  
**12 Lt**





- NERO - COD **SP1597215/A**
- BIANCO - COD **SP1597215/B**
- TORTORA - COD **SP1597215/C**

## PATTUMIERA A PEDALE IN PLASTICA DA 3 LITRI

*PLASTIC PEDAL DUSTBIN  
3 LITERS*

Pattumiera in plastica a pedale con cestino interno removibile. Disponibile in bianco, nero e tortora.

*Plastic pedal bin with removable inner bucket. Available in white, black and dove grey.*

<b>MISURE</b>	h 25,5 cm / ø 16 cm
---------------	---------------------

 pezzi / pieces <b>1</b>	 capacità / capacity <b>3 Lt</b>
--	--

## PATTUMIERA BASE TONDA A PEDALE IN ACCIAIO

*ROUND WHITE PEDAL STEEL  
BASE BIN*

**COD SP1580103**

Pattumiera in acciaio a pedale. Colore bianco.

*Pedal steel dustbin. White color.*

<b>MISURE</b>	h 24 cm / ø 16,8 cm
---------------	---------------------

 pezzi / pieces <b>6</b>	 capacità / capacity <b>3 Lt</b>
--	--



## PATTUMIERA A PEDALE IN ACCIAIO DA 5 LT

STEEL PEDAL  
DUSTBIN 5 LT

COD **SP1580015**

Pattumiera da bagno in acciaio con pedale. Finitura a specchio. Dotata di cestino interno removibile.

*Steel waste bathroom bin with pedal. Mirror finishing. Features removable inner bucket.*

<b>MISURE</b>	h 29 cm
---------------	---------

 pezzi / pieces  
**1**

 capacità / capacity  
**5 Lt**



## PATTUMIERA A PEDALE IN ACCIAIO DA 6 LT

STEEL PEDAL  
DUSTBIN 6 LT

COD **SP1580018**

Pattumiera da bagno in acciaio con pedale. Finitura a specchio. Dotata di cestino interno removibile.

*Steel waste bathroom bin with pedal. Mirror finishing. Features removable inner bucket.*

<b>MISURE</b>	h 29 cm
---------------	---------

 pezzi / pieces  
**1**

 capacità / capacity  
**6 Lt**



## PATTUMIERA A PEDALE IN ACCIAIO DA 6 LT

STEEL PEDAL  
DUSTBIN 6 LT

Pattumiera da bagno in acciaio a pedale con chiusura rallentata. Cestino interno removibile. Disponibile in bianco, nero e tortora.



*Pedal steel dustbin with slow down silent function. Removable inner bucket. Available in white, black and dove grey.*

<b>MISURE</b>	h 32,5 cm
---------------	-----------

 pezzi / pieces  
**1**

 capacità / capacity  
**6 Lt**



-  NERO - COD **SP1407522/A**
-  BIANCO - COD **SP1407522/B**
-  TORTORA - COD **SP1407522/C**





## PATTUMIERA A PEDALE PER RACCOLTA DIFFERENZIATA

*PEDAL BIN FOR WASTE  
SORTING*

COD **SP1592002**

Pattumiera in acciaio e polipropilene con pedale. Finitura satinata. Dotata di cestini interni removibili 2x12 Lt.

*Steel and polypropylene dustbin with pedal. Satin finishing. Features removable inner buckets 2x12 Lt.*

**MISURE**

h 45 cm

pezzi / pieces  
**1**

capacità / capacity  
**12 Lt x 2**



## PATTUMIERA A PEDALE PER RACCOLTA DIFFERENZIATA

*PEDAL BIN FOR WASTE  
SORTING*

COD **SP1592003**

Pattumiera in acciaio e polipropilene con pedale. Finitura satinata. Dotata di cestini interni removibili.

*Steel and polypropylene dustbin with pedal. Satin finishing. Features removable inner buckets 3x12 Lt.*

**MISURE**

h 45 cm

pezzi / pieces  
**1**

capacità / capacity  
**12 Lt x 3**

## PATTUMIERA A COLONNA IN ACCIAIO DA 25 LT

*PUSH OPEN DUSTBIN 25 LT  
MADE OF STAINLESS STEEL*

COD **SP1592025**

Pattumiera in acciaio cromato con finitura a specchio. Apertura a spinta. Dotata di cestello interno removibile.

*Steel dustbin with mirror finish. Push opening. Features removable inner bucket.*

<b>MISURE</b>	h 60 / Ø 25 cm
---------------	----------------



pezzi / pieces  
**1**



capacità / capacity  
**25 Lt**



## PATTUMIERA A COLONNA IN ACCIAIO DA 35 LT

*PUSH OPEN DUSTBIN 35 LT  
MADE OF STAINLESS STEEL*

COD **SP1592035**

Pattumiera in acciaio cromato con finitura a specchio. Apertura a spinta. Dotata di cestello interno removibile.

*Steel dustbin with mirror finish. Push opening. Features removable inner bucket.*

<b>MISURE</b>	h 66 / Ø 30 cm
---------------	----------------



pezzi / pieces  
**1**



capacità / capacity  
**35 Lt**



## PATTUMIERA A COLONNA IN ACCIAIO DA 50 LT

*PUSH OPEN DUSTBIN 50 LT  
MADE OF STAINLESS STEEL*

COD **SP1592050**

Pattumiera in acciaio cromato con finitura a specchio. Apertura a spinta. Dotata di cestello interno removibile.

*Steel dustbin with mirror finish. Push opening. Features removable inner bucket.*

<b>MISURE</b>	h 77 / Ø 35 cm
---------------	----------------



pezzi / pieces  
**1**



capacità / capacity  
**50 Lt**





## PATTUMIERA CON POSACENERE DA 18 LT

ASHTRAY DUSTBIN MADE  
OF STAINLESS STEEL 18 LT

COD **SP1407047**

Pattumiera-Posacenera a colonna in acciaio inossidabile con finitura a specchio. Posacenera incorporato removibile per una facile pulizia.

*Stainless steel dustbin-ashtray with mirror finish. Removable ashtray for easy cleaning.*

<b>MISURE</b>	h 59 / Ø 21 cm
---------------	----------------

pezzi / pieces  
**1**

capacità / capacity  
**18 Lt**

## PATTUMIERA CON POSACENERE DA 25 LT

ASHTRAY DUSTBIN MADE  
OF STAINLESS STEEL 25 LT

COD **SP1407049**

Pattumiera-Posacenera a colonna in acciaio inossidabile con finitura a specchio. Posacenera incorporato removibile per una facile pulizia.

*Stainless steel dustbin-ashtray with mirror finish. Removable ashtray for easy cleaning.*

<b>MISURE</b>	h 60 / Ø 24 cm
---------------	----------------

pezzi / pieces  
**1**

capacità / capacity  
**25 Lt**



# ARREDO BAGNO

*Bathroom furniture*

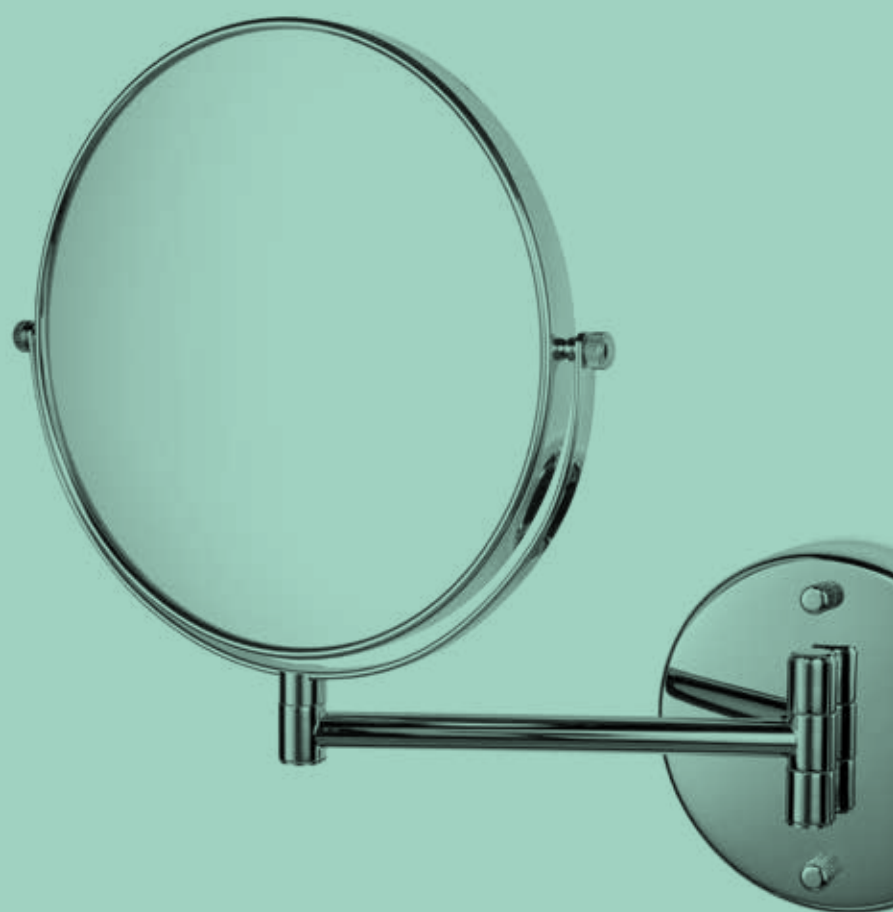

## SPECCHIO INGRANDITORE DA BAGNO

ONE BRACKET STAINLESS STEEL  
MAGNIFYING MIRROR

COD **MR1**

Specchio ingranditore in acciaio Inox. Braccio singolo. Finitura cromata lucida. Ingrandimenti: un lato 1X, altro lato 3X.

*One bracket stainless steel magnifying mirror. Finishing: polished chrome. Magnification: one side 1X, the other side 3X.*

**MISURE**

Ø 20 cm



pezzi / pieces  
**1**

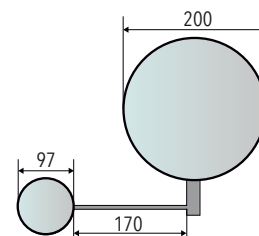
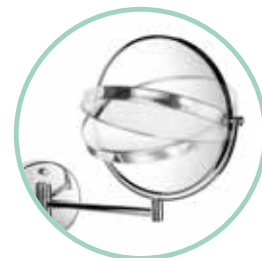

## SPECCHIO INGRANDITORE CON BRACCIO SNODATO

TWO BRACKETS STAINLESS STEEL  
MAGNIFYING MIRROR

COD **MR2**

Specchio ingranditore in acciaio Inox. Doppio braccio snodato. Finitura cromata lucida. Ingrandimenti: un lato 1X, altro lato 3X.

*Two brackets stainless steel magnifying mirror. Polished chrome finishing. Magnification one side 1X, the other side 3X.*

**MISURE**

Ø 20 cm



pezzi / pieces  
**1**

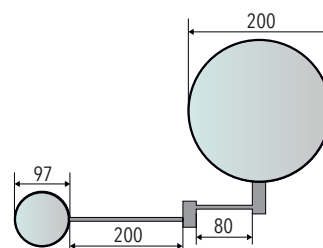

## FASCIATOIO DA PARETE RICHIUDIBILE

BABY CHANGING STATION  
CERTIFIED BY TUV SUD

COD **FH**

Fasciatoio in HDPE. Ottima resistenza all'usura. Carico massimo 22,70 kg. Rispetta la direttiva CE standard secondo l'allegato V della direttiva 93/42/EEC relativa alla dichiarazione di conformità CE (garanzia di qualità della produzione). Marchio di certificazione TUV SUD.

*Made in HDPE. High resistance to weathering. Maximum loading 22,70 kg. It complies with the EC Directive standards according to Annex V of Directive 93/42/EEC on the EC declaration of conformity (guarantee of production quality). TUV SUD certification mark.*

**MISURE**

**aperto**  
h 48 x p 54 x l 85 cm

**chiuso**  
h 54 x p 8,5 x l 85 cm



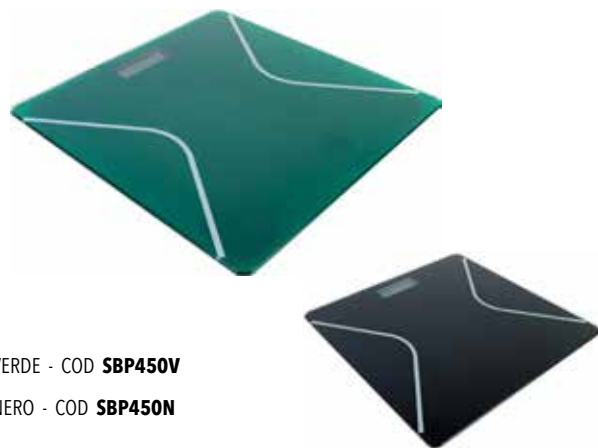

- VERDE - COD **SBP450V**
- NERO - COD **SBP450N**

## BILANCIA PESAPERSONE CON DISPLAY DIGITALE

WEIGHING SCALE WITH DIGITAL DISPLAY

Bilancia pesapersona. Pesa fino a 180 Kg. Dotata di display digitale. La digitalizzazione dello strumento offre una precisione altissima durante la pesatura. Peso 2 kg.

*Weighing scale. Features a digital display. Max. weight capacity 180 kg. The digitalisation of the instrument offers very high precision during weighing. Weight 2 kg.*

**MISURE** h 10 x p 26 x l 24,5 cm

pezzi / pieces **1**



- NERO - COD **SB1407314/A**
- BIANCO - COD **SB1407314/B**
- TORTORA - COD **SB1407314/C**

## BILANCIA PESAPERSONE CON TOP IN VETRO

WEIGHING SCALE WITH TEMPERED GLASS TOP

Bilancia pesapersona in vetro temperato 5 mm. Dotata di una batteria al litio a bottone CR2032, 3 V. Disponibile in nero, bianco e tortora. Portata massima: 150 kg.

*Body scale made of 5 mm tempered glass. Features one CR2032 button lithium battery, 3 V. Available in black, white and dove grey. Max. weight capacity: 150 kg.*

**MISURE** h 1,7 x p 30 x l 30 cm

pezzi / pieces **10**

## VASCHETTA REGGISAPONE ANGOLARE

ANGLED STEEL  
SOAP BASKET

COD **B001**

Portaoggetti angolare in acciaio Inox. Finitura cromata lucida.

*Angle, stainless steel basket. Polished chrome finish.*

**MISURE**

h 5 x p 17,5 x l 27cm



pezzi / pieces  
**1**

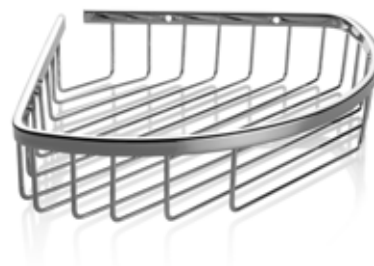

## VASCHETTA REGGISAPONE RETTANGOLARE

RECTANGULAR STEEL  
SOAP BASKET

COD **B002**

Portaoggetti rettangolare in acciaio Inox. Finitura cromata lucida.

*Rectangular, stainless steel basket. Polished chrome finish.*

**MISURE**

h 7 x p 14 x l 30 cm



pezzi / pieces  
**1**

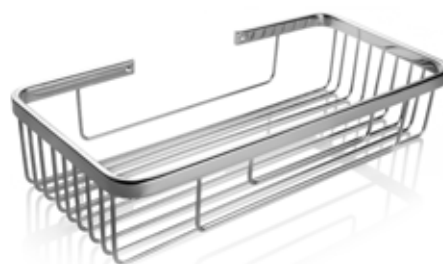

## VASCHETTA ANGOLARE CON VENTOSE

CORNER SHELF WITH  
SUCTION CUPS

COD **SM1407315**

Vaschetta cromata, finitura a specchio.

*Chromed tray, mirror finish.*

**MISURE**

h 18 x p 11 x l 18 cm



pezzi / pieces  
**24**







## VASCHETTA CON VENTOSE

SHELF WITH  
SUCTION CUPS

COD **SM1407311**

Vaschetta cromata, finitura a specchio.

Chromed tray, mirror finish.

**MISURE** h 24 x p 10 x l 16,5 cm

pezzi / pieces  
**24**



## REGGISAPONE CON VENTOSA

SOAP SHELF WITH  
SUCTION CUP

COD **SP1407314**

Reggisapone cromato, finitura a specchio.

Chrome soap shelf, mirror finish.

**MISURE** h 13 x p 5,5 x l 9,5 cm

pezzi / pieces  
**12**



## PORTAOGGETTI CON GANCIO A 2 RIPIANI

TWO SHELVES  
WITH HOOK

COD **SM1407310**

Portaoggetti cromato, finitura a specchio.

Chrome holder, mirror finish.

**MISURE** h 43 x p 10 x l 24 cm

pezzi / pieces  
**12**

## APPENDINO SINGOLO CON VENTOSA

*SINGLE HOOK WITH  
SUCTION CUP*

COD **SA1407313**

Appendino singolo cromato, finitura a specchio.

*Single chrome hook, mirror finish.*

**MISURE** h 11,5 x p 4,5 x l 5,5 cm

pezzi / pieces  
**48**



## PIANTANA PORTA ASCIUGAMANI CON BASE COLORATA

*CHROME TOWEL HOLDER  
WITH COLORED BASE*

Piantana porta asciugamani in acciaio con base rettangolare in vetro temperato 8 mm. Con due braccia. Disponibile con base bianca, nera o tortora.

*Steel towel holder with 8 mm toughened glass base. Available with white, black or dove grey base.*

**MISURE** h 70,5 x p 18 x l 22 cm

pezzi / pieces  
**6**



- NERO - COD **SP1407429/A**
- BIANCO - COD **SP1407429/B**
- TORTORA - COD **SP1407429/C**

## PIANTANA PORTA ASCIUGAMANI CON BASE QUADRATA

*DOUBLE TOWEL HOLDER  
WITH SQUARE BASE*

COD **SP1592244**

Piantana porta asciugamani in acciaio. Con due braccia. Finitura a specchio.

*Steel towel holder. With two arms. Mirror finish.*

**MISURE** h 91 x p 18 x l 35 cm

pezzi / pieces  
**6**





## PIANTANA PORTA ASCIUGAMANI CON 3 BRACCI

TRIPLE TOWEL HOLDER WITH ROUND BASE

COD **SP1592246**

Piantana porta asciugamani in acciaio a base rotonda. Con tre braccia. Finitura a specchio.

*Steel towel holder. With three arms. Mirror finish.*

**MISURE**

h 88 / Ø 23 cm



pezzi / pieces  
**4**



## PIANTANA PORTA ASCIUGAMANI CON 3 BRACCI

TRIPLE TOWEL HOLDER WHITE

COD **SP1592346**

Piantana porta asciugamani in acciaio a base rotonda. Con tre braccia. Colore bianco.

*Steel towel holder. With triple towel. White color.*

**MISURE**

h 85,8 / Ø 22 cm



pezzi / pieces  
**4**



## PORTAROTOLO CARTA IGIENICA CON VENTOSA

TOILET PAPER HOLDER WITH SUCTION CUP

COD **SG1407312**

Portarotolo carta igienica cromato, finitura a specchio. Con ventosa.

*Chrome toilet paper holder, mirror finish. With suction cup.*

**MISURE**

h 13 x p 3,5 x l 15 cm



pezzi / pieces  
**24**

## PORTASCOPINO COLORE BIANCO

TOILET BRUSH  
WHITE COLOR

COD **SP1592175**

Portascopino in acciaio. Colore bianco.

*Steel toilet brush holder. White color.*

**MISURE**

h 38,5 / Ø 9,5 cm



pezzi / pieces  
**24**



## PORTASCOPINO CON FINITURA A SPECCHIO

TOILET BRUSH HOLDER WITH  
MIRROR FINISH

Portascopino in acciaio, finitura a specchio. Semplice o forato.

*Steel toilet brush holder, mirror finish. Simple or perforated.*

**MISURE**

h 39 / Ø 10 cm



pezzi / pieces  
**24**



● SEMPLICE - COD **SP1592075**

■ FORATO - COD **SP1592078**

## PIANTANA MULTIFUNZIONE COLORE BIANCO

TOILET BRUSH AND TOILET PAPER  
HOLDER IN WHITE COLOR

COD **SP1592350**

Piantana in acciaio con portascopino e alloggio per carta igienica. Colore bianco.

*Steel holder with toilet brush holder and toilet paper holder. Color white.*

**MISURE**

h 80 / Ø 22 cm



pezzi / pieces  
**6**





## PIANTANA MULTIFUNZIONE IN ACCIAIO

TOILET BRUSH AND TOILET PAPER  
HOLDER

COD **SP1592250**

Piantana in acciaio con portascopino e alloggio per carta igienica. Con base rotonda. Finitura a specchio.

*Steel multifunctional holder with toilet brush and toilet paper. With round base. Mirror finish.*

**MISURE**

h 80 / Ø 22 cm



pezzi / pieces  
**6**



## PIANTANA MULTIFUNZIONE IN ACCIAIO

TOILET BRUSH AND TOILET PAPER  
HOLDER

COD **SP1592065**

Piantana in acciaio con portascopino e alloggio per carta igienica. Con base quadrata. Finitura a specchio.

*Steel multifunctional holder with toilet brush and toilet paper. With square base. Mirror finish.*

**MISURE**

h 71 x p 18 x l 22 cm



pezzi / pieces  
**6**



● NERO - COD **SP1407430/A**

○ BIANCO - COD **SP1407430/B**

● TORTORA - COD **SP1407430/C**

## PIANTANA MULTIFUNZIONE CON BASE COLORATA

MULTIFUNCTIONAL HOLDER  
WITH COLORED BASE

Piantana in acciaio cromato con portascopino e alloggio per carta igienica. Base quadrata in vetro temperato 8 mm. Disponibile con base bianca, nera o tortora.

*Steel multifunctional holder with toilet brush and toilet paper. 8 mm tempered glass square base. Available with white, black, or dove grey base.*

**MISURE**

h 70,5 x p 18 x l 22 cm



pezzi / pieces  
**4**



# ARREDO CAMERA

*Furniture for bedroom*



## LETTINO PER BEBÈ RICHIUDIBILE IN LEGNO DI PINO

FOLDABLE WOOD  
BABY BED

COD **BABYBOXP**

Letto richiudibile da camera per bebè in legno con materassino incluso. Materassino altezza 3 cm. Dimensioni interne 90 x 60 cm. Peso netto 13 kg.

*Foldable wood baby bed with mat included. Mat height 3 cm included. Inner size 90 x 60 cm. Net weight 13 kg.*

**MISURE** h 96.5 x l 101 x p 66 cm

pezzi / pieces  
**1**



## LETTINO PER BEBÈ RICHIUDIBILE IN ACCIAIO

FOLDABLE STEEL  
BABYBOX

COD **BABYBOX**

Letto richiudibile da camera per bebè in acciaio e plastica con reti laterali di protezione. Certificazione EN716. Peso netto 7,7 kg.

*Foldable steel and plastic babybox with two sides mesh. EN716 certification. Net weight 7,7 kg.*

**MISURE** h 77 x l 124 x p 65 cm

pezzi / pieces  
**1**







## SEGGIOLONE BIANCO PER BEBÈ

WHITE BABY  
HIGH CHAIR

COD **BCHAIR**

Seggiolone per bebè in plastica e metallo. Certificato EN14988 e EN71. Adatto a bambini da 6 mesi a 6 anni. Materiale PP, PU e metallo. Peso 3,6 Kg.

*Plastic and metal baby high chair. Certified EN14988 and EN71. Applicable for children from 6 months to 6 years. Material PP, PU and metal. Weight 3,6 kg.*

**MISURE**

h 87 x l 54 x p 64 cm



pezzi / pieces  
**1**

## GRUCCIA IN LEGNO CON GANCIO RICURVO

WOOD HANGER  
WITH CURVED HOOK

COD **GR**

Gruccia in legno di acero. Testa ricurva con gancio cromato. Tubo antiscivolo trasparente su barra e tacche sulle spalle. Occhiello da 38 mm.

*Hanger with maple finish. Curved head with chrome hook. Transparent non-slip tube on bar and notches on shoulders. Eye 38 mm.*

MISURE

l 44,5 x p 1,2 cm



pezzi / pieces  
**100**



## GRUCCIA IN LEGNO CON GANCIO ANTIFURTO

WOODEN HANGER WITH  
ANTI-THEFT HOOK RING

Gruccia in legno con testa curva. Anello cromato anti-furto. Tubo antiscivolo trasparente su barra e tacche sulle spalle. Diametro interno dell'anello 38 mm.

*Hanger with curved head. Chrome plated anti-theft ring. Transparent non-slip tube on bar and notches on shoulders. Hook ring 38 mm.*

MISURE

l 44,5 x p 1,2 cm



pezzi / pieces  
**100**



● ACERO - COD **GRA**

● NOCE - COD **GRA-1**

## GRUCCIA IN LEGNO CON GANCIO ANTIFURTO E PINZE

WOODEN HANGER WITH ANTI-THEFT  
RING AND TROUSER PINCERS

Gruccia in legno con testa curva. Anello cromato anti-furto. Tubo, pinze reggi-pantaloni in acciaio cromato e tacche sulle spalle. Diametro interno dell'anello 38 mm.

*Hanger with curved head. Chrome-plated anti-theft ring. Tube, chrome-plated steel trouser pincers and notches on shoulders. Hook ring 38 mm.*

MISURE

l 44,5 x p 1,2 cm



pezzi / pieces  
**100**



● ACERO - COD **GRAP**

● NOCE - COD **GRAP-1**



- NERO - COD **SG1780038/N**
- BIANCO - COD **SG1780038/B**

## SET DI 2 GRUCCE IN ABS CON GANCIO RICURVO

*SET OF 2 ABS HANGERS  
WITH CURVED HOOK*

2 grucce in ABS con gancio cromato. Disponibile in nero e bianco. Con reggi-bretella da 38,5 cm.

*Set of 2 ABS hangers with curved hook and 38.5 cm suspender rail. Available in black and white.*

**MISURE**

h 23 x l 38,5 cm



pezzi / pieces  
**60**



- NERO - COD **SG1781015/N**
- BIANCO - COD **SG1781015/B**

## GRUCCIA IN LEGNO CON ASTA APPENDI- PANTALONI

*WOODEN HANGER WITH  
TROUSER HANGER ROD*

Gruccia in legno verniciato. Disponibile in nero e bianco. Con gancio ricurvo e asta appendi-pantaloni.

*Painted wooden hanger. Available in black and white. With curved hook and trouser hanger rod.*

**MISURE**

h 24 x l 45 cm



pezzi / pieces  
**20**



- NERO - COD **SG1781003/N**
- BIANCO - COD **SG1781003/B**

## SET DI 3 GRUCCE IN LEGNO CON ASTA APPENDI-PANTALONI

*SET OF 3 WOODEN  
WITH TROUSER HANGER ROD*

Grucce in legno verniciato. Disponibile in nero e bianco. Con gancio ricurvo e asta appendi-pantaloni.

*Painted wooden hanger. Available in black and white. With curved hook and trouser hanger rod.*

**MISURE**

h 23 x l 45 cm



pezzi / pieces  
**32**

## SET DI 2 GRUCCE IN ABS CON GANCIO RICURVO

SET OF 2 ABS HANGERS  
WITH CURVED HOOK

2 grucce in ABS con gancio cromato. Disponibile in nero e bianco. Con reggi-bretella da 46 cm.

2 ABS hangers with chrome hook. Available in black and white. With suspender 46 cm.

**MISURE**

h 23 x l 46 cm



pezzi / pieces  
**60**



- NERO - COD **SG1780043/N**
- BIANCO - COD **SG1780043/B**

## SET DI 2 GRUCCE IN ABS CON PINZE REGGI-PANTALONI

SET OF 2 ABS HANGERS WITH  
TROUSER CLAMPS

2 grucce in ABS con gancio cromato. Disponibile in nero e bianco. Con pinze reggi-pantaloni.

2 ABS hangers with chromed hook. Available in black and white. With trouser clamps.

**MISURE**

h 18 x l 36,5 cm



pezzi / pieces  
**96**



- NERO - COD **SG1780036/N**
- BIANCO - COD **SG1780036/B**



NERO CON FARFALLE  
COD **SP1817240**



NERO CON GOCCE  
COD **SP1817234**



NERO CON SCRITTE  
COD **SP1817289**



BIANCO CON FARFALLE  
COD **SP1817239**



BIANCO CON GOCCE  
COD **SP1817233**



BIANCO CON SCRITTE  
COD **SP1817290**

## PORTAOMBRELLI IN ACCIAIO A BASE TONDA

STEEL UMBRELLA HOLDER  
WITH ROUND BASE

Portaombrelli in acciaio verniciato con decorazioni intagliate, colore nero.

*Painted steel umbrella holder with carved decoration, black color.*

MISURE

h 46 / Ø 18 cm



pezzi / pieces  
**4**

## PORTAOMBRELLI IN ACCIAIO A BASE QUADRATA

STEEL UMBRELLA HOLDER  
WITH SQUARE BASE

Portaombrelli in acciaio verniciato con decorazioni intagliate, colore bianco.

*Painted steel umbrella holder with carved decoration, white color.*

MISURE

h 49 x p 15,5 x l 15,5 cm



pezzi / pieces  
**4**



# COLONNINE SEGNAPERCORSO

*Crowd control post*

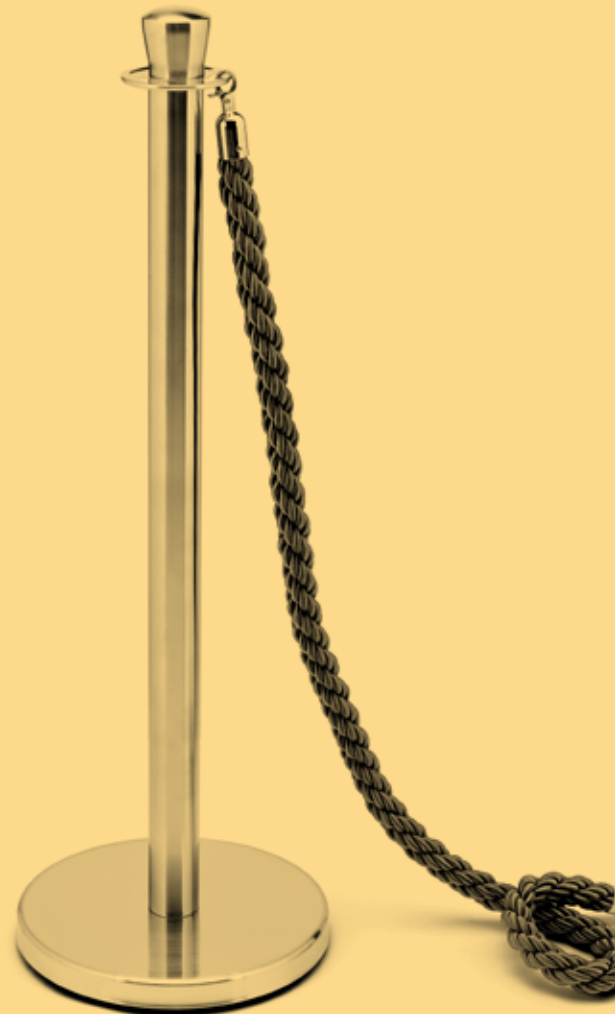

## COLONNINA SEGNAPERCORSO IN ACCIAIO

STEEL CROWD CONTROL POST

COD **COLONNANYLON**

Colonnina segnapercorso in acciaio cromato con tendinastro integrato e base zavorrata. Nastro di colore nero lungo 2 m. Ø tubo 4,4 cm. Possibilità di applicare un pannello informativo.

*Steel crowd control post with integrated belt tensioner and weighted base. Chrome steel crowd control post. Black belt. Weighted base. Tube diameter 4,4 cm. Belt length 2 m. Possibility to apply an information board.*

**MISURE**

h 95 cm / ø 31 cm



pezzi / pieces  
2



## COLONNINA SEGNAPERCORSO IN ACCIAIO DORATO

BRUSHED GOLD STEEL CROWD  
CONTROL POST

COD **COLONNAGOLD**

Colonnina segnapercorso in acciaio satinato dorato e base zavorrata. Cordone non incluso. Testa svitabile sagomata. Ø del tubo 5 cm. Possibilità di applicare un pannello informativo.

*Brushed steel crowd control post with rings and weighted base. Cord not included. Screwable shaped head with 4 fixing points for hooks. Tube diameter 5 cm. Weighted base.*

**MISURE**

h 95 cm / ø 32 cm



pezzi / pieces  
2



4 PUNTI DI FISSAGGIO GANCI  
4 OPENINGS FOR ROPE CLIP ENDS

## COLONNINA SEGNAPERCORSO IN ACCIAIO SILVER

BRUSHED SILVER STEEL CROWD  
CONTROL POST

COD **COLONNASILVER**

Colonnina segnapercorso in acciaio satinato dorato e base zavorrata. Cordone non incluso. Testa svitabile sagomata. Ø del tubo 4,4 cm. Possibilità di applicare un pannello informativo.

*Brushed steel crowd control post with rings and weighted base. Cord not included. Screwable shaped head with 4 fixing points for hooks. Tube diameter 44 mm. Weighted base.*

**MISURE**

h 95 cm / ø 31 cm



pezzi / pieces  
2



4 PUNTI DI FISSAGGIO GANCI  
4 OPENINGS FOR ROPE CLIP ENDS





- BLU SCURO - COD **CORDAG-B2**
- DORATO - COD **CORDAG-C**
- ROSSO SCURO - COD **CORDAG-R2**
- NERO - COD **CORDAG-N**



- BLU SCURO - COD **CORDAS-B2**
- DORATO - COD **CORDAS-C**
- ROSSO SCURO - COD **CORDAS-R2**
- NERO - COD **CORDAS-N**

## CORDONE INTRECCIATO IN NYLON CON MOSCHETTONI DORATI

*BRAIDED NYLON CORD WITH GOLD FINISH CARABINERS*

Cordone in corda intrecciata in nylon per colonnine segna-percorso. Moschettoni in lega di cromo, finiture dorate. Peso 1,5 Kg. Disponibile in vari colori. Venduti imbustati singolarmente.

*Braided nylon cord for crowd control post. Weight 1,5 kg. Chrome carabiners, gold finish. Available in various colors. Sold individually packed.*

<b>MISURE</b>	l 150 cm / ø 3,2 cm	pezzi / pieces <b>1</b>
---------------	---------------------	----------------------------

## CORDONE INTRECCIATO IN NYLON CON MOSCHETTONI IN ARGENTO CROMATO

*BRAIDED NYLON CORD WITH CHROME CARABINERS*

Cordone in corda intrecciata in nylon per colonnine segna-percorso. Moschettoni in lega di cromo, finiture cromate. Peso 1,5 Kg. Disponibile in vari colori. Venduti imbustati singolarmente.

*Braided nylon cord for crowd control post. Weight 1,5 kg. Chrome carabiners, cromo finish. Available in various colors. Sold individually packed.*

<b>MISURE</b>	l 150 cm / ø 3,2 cm	pezzi / pieces <b>1</b>
---------------	---------------------	----------------------------





# LAMPADE

*Lamps*



## LAMPADA DA TAVOLO WIRELESS A BASE STONDATA

WIRELESS LONG LIFE BATTERY  
TABLE LAMP WITH ROUNDED BASE

Lampada LED da tavolo senza fili a batteria lunga durata con regolazione touch e base stondata. 3 intensità regolabili. 3 temperature colore regolabili. Fino a 30 ore di autonomia. Metallo rifinito in bagno galvanico con vernice spray. LED a bassissimo consumo. Batteria 1800 mAh per durata dalle 15 alle 25 ore. Completa di cavo di ricarica usb e manuale d'uso.

*Wireless long life battery table lamp with touch adjustment and rounded base. 3 adjustable intensities. 3 adjustable color temperatures. Up to 30 hours of autonomy. Metal finished in galvanic bath with spray paint. LED elements with very low consumption. Battery 1800 mAh for duration from 15 to 25 hours. Usb charging cable and user manual.*

MISURE

h 37,2 cm / Ø 9 cm



pezzi / pieces  
1



-  DORATO - COD **MAGICLAMP1G**
-  SILVER - COD **MAGICLAMP1S**
-  NERO - COD **MAGICLAMP1N**
-  BIANCO - COD **MAGICLAMP1W**

## LAMPADA DA TAVOLO WIRELESS A BASE CILINDRICA

WIRELESS LONG LIFE BATTERY TABLE  
LAMP WITH CYLINDRICAL BASE

Lampada LED da tavolo senza fili a batteria lunga durata con regolazione touch e base cilindrica. 3 intensità regolabili. 3 temperature colore regolabili. Fino a 30 ore di autonomia. Metallo rifinito in bagno galvanico con vernice spray. LED a bassissimo consumo. Batteria 1800 mAh per durata dalle 15 alle 25 ore. Completa di cavo di ricarica usb e manuale d'uso.

*Wireless long life battery operated table lamp with touch adjustment and cylindrical base. 3 adjustable intensities. 3 adjustable color temperatures. Up to 30 hours of autonomy. Metal finished in galvanic bath with spray paint. LED elements with very low consumption. Battery 1800 mAh for duration from 15 to 25 hours. Usb charging cable and user manual.*





MISURE

h 37,2 cm / Ø 9 cm



pezzi / pieces  
1



-  DORATO - COD **MAGICLAMP2G**
-  SILVER - COD **MAGICLAMP2S**
-  NERO - COD **MAGICLAMP2N**
-  BIANCO - COD **MAGICLAMP2W**



-  DORATO - COD **MAGICLAMP3G**
-  SILVER - COD **MAGICLAMP3S**
-  NERO - COD **MAGICLAMP3N**
-  BIANCO - COD **MAGICLAMP3W**

## LAMPADA DA TAVOLO WIRELESS CON PARALUME CONICO

WIRELESS LONG LIFE BATTERY TABLE LAMP WITH CONICAL LENS HOOD

Lampada LED da tavolo senza fili a batteria lunga durata con regolazione touch e paralume conico. 3 intensità regolabili. 3 temperature colore regolabili. Fino a 30 ore di autonomia. Metallo rifinito in bagno galvanico con vernice spray. LED a bassissimo consumo. Batteria 1800 mAh per durata dalle 15 alle 25 ore. Completa di cavo di ricarica usb e manuale d'uso.

*Wireless LED long-life battery table lamp with touch adjustment and conical lens hood. 3 adjustable intensities. 3 adjustable color temperatures. Up to 30 hours of autonomy. Metal finished in galvanic bath with spray paint. LED elements with very low consumption. Battery 1800 mAh for duration from 15 to 25 hours. Usb charging cable and user manual.*

**MISURE** h 37,2 cm / Ø 9 cm

 pezzi / pieces **1**

## LAMPADA DA TAVOLO WIRELESS RICARICABILE USB

WIRELESS USB RECHARGEABLE TABLE LAMP



Lampada da tavolo ricaricabile con cavo USB e adattatore. Struttura in alluminio, diffusore in PMMA e fonte luminosa a LED (48 punti luce). Accensione, regolazione colore e intensità tramite pulsante "Touch". Pulsante con memoria dimmer, temperatura colore luce regolabile (2700 o 3000K). Tempo di carica 5 ore. Durata carica 15/20 ore. Potenza 3,5 W. Flusso luminoso: 200-220 lm. Classe III. Grado di protezione IP54.

*Rechargeable table lamp, with USB connection and plug adapter. Body made of aluminium, diffuser made of PMMA, and Led light (with 48 pcs LED light). "Touch" switch to turn the lamp on, to adjust color of the light and to dimmer light. Dimmer switch with memory function, adjustable light temperature (2700 or 3000K). Charging duration 5 hours. Battery duration 15-20 hours. Power 3,5 W. Luminous flux 200-220 lm. Class III. Protection class IP54.*

**MISURE** h 38 cm  
base 10 cm x 10 cm

 pezzi / pieces **1**



-  RUGGINE - COD **SL1776621**
-  NERO - COD **SL1776620**
-  BIANCO - COD **SL1776619**



## LAMPADA DA TAVOLO WIRELESS A BASE CILINDRICA

WIRELESS ACRYLIC TABLE LAMP  
WITH CYLINDRICAL BASE

COD **MAGICLAMP4W**

Lampada LED da tavolo senza fili a batteria lunga durata con regolazione touch e base cilindrica. 3 intensità regolabili. 3 temperature colore regolabili. Fino a 30 ore di autonomia. Metallo rifinito in bagno galvanico con vernice spray. LED a bassissimo consumo. Batteria 1800 mAh per durata dalle 15 alle 25 ore. Completa di cavo di ricarica usb e manuale d'uso.

*Wireless acrylic table lamp with long battery life with touch adjustment and cylindrical base. 3 adjustable intensities. 3 adjustable color temperatures. Up to 30 hours of autonomy. Metal finished in galvanic bath with spray paint. LED elements with very low consumption. Battery 1800 mAh for duration from 15 to 25 hours. Usb charging cable and user manual.*

### MISURE

h 37,2 cm / Ø 9 cm



pezzi / pieces  
**1**



## LAMPADA DA TAVOLO A LED RICARICABILE DOPPIA ALTEZZA

DOUBLE HEIGHT RECHARGEABLE  
LED TABLE LAMP

Lampada da tavolo ricaricabile con cavo USB. Stelo smontabile per poter ottenere due lampade in una: una di altezza 38 cm e l'altra da 24 cm. Dotata di base in gomma antigraffio e antisdrucciolo. Struttura in acciaio, diffusore in PE e fonte luminosa a LED. Accensione, regolazione colore e intensità tramite pulsante. Temperatura di colore luce regolabile (2700-3000-4000K). Regolazione intensità del flusso luminoso su tre livelli. Tempo di carica 4-5 ore. Durata carica 5 ore a massima luminosità, 10 ore a luminosità media e 20 ore a luminosità minima. Potenza 1,2 W. Flusso luminoso 100 lm. Grado di protezione IP44.

*Rechargeable table lamp with USB cable. Stem can be entirely dismantled to obtain two lamps in one: a 38 cm high and a lower 24 cm. Equipped with an anti-scratch and anti-slip rubber base. Steel frame, PE diffuser and LED light source. Switching, color and intensity adjustment via push-button. Adjustable light color temperature (2700-3000-4000K). Light intensity adjustment on three levels. Charging duration 4-5 hours. Battery duration 5 hours at maximum brightness, 10 hours at medium brightness and 20 hours at minimum brightness. Power 1.2 W. Luminous flux 100 lm. Protection class IP44.*

### MISURE

h 38 - h 24 cm  
base 12 cm x 12 cm





pezzi / pieces  
**6**



- BIANCO - COD **SL1776630**
- ANTRACITE - COD **SL1776631**
- SALVIA - COD **SL1776632**



-  ORO - COD **SL1776290**
-  ARGENTO - COD **SL1776291**
-  NERO - COD **SL1776292**

## LAMPADA A SOSPENSIONE DIAMETRO 5 CM

LED PULL CORD LIGHT WITH  
A DIAMETER OF 5 CM



Lampada a LED con corda. Azionabile con un semplice clic. Adatta per illuminare qualsiasi tipo di ambiente. Funziona con tre batterie AAA (non incluse).

*Led pull cord light LED lamp with cord. Operated with a simple click. Suitable for illuminating any type of environment. Requires three AAA batteries (not included).*

<b>MISURE</b>	h 130 cm / Ø 5 cm
---------------	-------------------

 pezzi / pieces  
**48**



-  ORO - COD **SL1776827**
-  ARGENTO - COD **SL1776828**
-  NERO - COD **SL1776829**

## LAMPADA A SOSPENSIONE DIAMETRO 10 CM

LED PULL CORD LIGHT WITH  
A DIAMETER OF 10 CM

Lampada a LED con corda. Azionabile con un semplice clic. Adatta per illuminare qualsiasi tipo di ambiente. Funziona con tre batterie AAA (non incluse).

*Led pull cord light LED lamp with cord. Operated with a simple click. Suitable for illuminating any type of environment. Requires three AAA batteries (not included).*

<b>MISURE</b>	h 130 cm / Ø 10 cm
---------------	--------------------

 pezzi / pieces  
**36**



## LANTERNA IN BAMBÙ PANCIUTA

*BAMBOO BELLIED  
LANTERN*

Lanterna in bambù con bicchiere. Disponibile in bianco o colore naturale.

*Bamboo lantern with glass. Available in white or natural color.*

**MISURE**

h 39 cm / Ø 20 cm



pezzi / pieces  
**12**



NATURALE - COD **SL1766338**

BIANCO - COD **SL1766337**

## LANTERNA IN BAMBÙ A CILINDRO

*BAMBOO CYLINDER  
LANTERN*

Lanterna in bambù con bicchiere. Disponibile in bianco o colore naturale.

*Bamboo lantern with glass. Available in white or natural color.*

**MISURE**

h 54 cm / Ø 20 cm



pezzi / pieces  
**8**



NATURALE - COD **SL1766336**

BIANCO - COD **SL1766335**





● NATURALE - COD **SL1766340**

○ BIANCO - COD **SL1766339**



## LANTERNA IN BAMBÙ TONDA

*BAMBOO ROUND  
LANTERN*

Lanterna in bambù con bicchiere. Disponibile in bianco o colore naturale.

*Bamboo lantern with glass. Available in white or natural color.*

**MISURE**

h 40 cm / Ø 26 cm



pezzi / pieces  
**12**





# RISCALDAMENTO PER ESTERNO

*Outdoor heating*



## RISCALDATORE DA ESTERNO A GPL

LPG OUTDOOR  
HEATER

COD **SFR1**

Riscaldatore da esterno con riflettore ad ombrello da 810 mm di diametro. Alimentato a gas gpl. Bruciatore in acciaio Inox 304 per alte temperature (Ø 275 x h 530 mm). Vano portabombola 15 kg. Completo di tubo e regolatore di pressione. Con ruote di spostamento e sistema di sicurezza anti ribaltamento. Spegnimento automatico di sicurezza. Potenza 12kW - 450 - 870 gr/hr.

*Outdoor heating with reflector 810 mm in diameter. Operates on LPG gas. 304 stainless steel burner for high temperatures (Ø 275 x h 530 mm). Cylinder compartment 15 kg. Complete with hose and pressure regulator. With moving wheels and system safety against tipping. Automatic switching off of safety. Power 12kW - 450 - 870 gr/hr.*

**MISURE**

h 221 cm / Ø 81 cm



peso netto /  
net weight  
**17,5 kg**



## RISCALDATORE DA ESTERNO A GPL

LPG OUTDOOR  
HEATER

COD **SFR2**

Riscaldatore da esterno con riflettore a ombrello e diffusore cilindrico. Fiamma a distribuzione circolare del calore. Alimentato a gas gpl. Completo di tubo e regolatore di pressione. Con ruote di spostamento. Riflettore 8 x 105 mm. Tubo in vetro 100 x 1068 mm. Vano portabombola 15 kg. Potenza 12 - 13 kW / 945 gr/hr. Colore golden, corpo in acciaio.

*Flame with circular heat distribution. Operates on LPG gas. Complete with hose and pressure regulator. With moving wheels. Reflector 8 x 105 mm. Glass tube 100 x 1068 mm. Cylinder compartment 15 kg. Power 12 - 13 kW - 945 gr/hr. Color golden, steel body.*

**MISURE**

h 218 cm / Ø 82 cm



peso netto /  
net weight  
**21 kg**





LAMPADA A INFRAROSSI  
INFRARED LAMP

## RISCALDATORE DA ESTERNO DI DESIGN CON LAMPADA A INFRAROSSI

DESIGN OUTDOOR HEATER  
WITH INFRARED LAMP

COD **S6459810000**

Riscaldatore da esterno di design in alluminio e acciaio con lampada a infrarossi. Struttura nero opaco, interruttore a bilanciere. Potenza 220 - 240 V - 50 Hz. Impostazioni 1500 W. Palo fisso 2 m. Per uso esterno, con funzione impermeabile e omologazione ip55. Cavo da 1,9 m. Con certificato CE/EMC/PAHS/ROHS/LVD.

*Outdoor heater with matt black aluminium and steel frame, push-button switch. Power 220 - 240 V - 50 Hz. Settings: 1500 W. Pole fixed 2 m. Cable 1.9 m. For outdoor use, with waterproof function and IP55 approval. With certification CE/EMC/PAHS/ROHS/LVD.*

**MISURE**

h 205 cm / Ø 50 cm



peso netto /  
net weight  
**13,6 kg**

## RISCALDATORE DA ESTERNO COMPATTO DA PARETE

COMPACT OUTDOOR ALUMINIUM  
WALL HEATER

COD **S6460750000**

Riscaldatore compatto a parete in alluminio con telecomando e timer. Alimentazione 220 - 240 v - 50 Hz. 3 diverse impostazioni: 500 W - 1000 W - 1500 W. Con lampada alogena per uso esterno, funzione impermeabile. Certificazione CE.

*Aluminium wall heater with remote control and timer. Power supply 220 - 240 v - 50 Hz. 3 different settings: 500 W - 1000 W - 1500 W. With halogen lamp for outdoor use, waterproof function. Certification CE.*



CON TELECOMANDO  
WITH REMOT CONTROL

**MISURE**

171 x p 13,5 x h 17



peso netto /  
net weight  
**2,2 kg**



# PIANTE ARTIFICIALI

*Artificial plants*



## PIANTA SANSEVIERIA

SANSEVIERIA  
PLANT

COD **SP2150074**

Pianta sansevieria da interno in polietilene. 12 foglie.  
Vaso con muschio.

*Polyethylene indoor sansevieria plant. 12 leaves. Pot with moss.*

**ALTEZZA**

45 cm



peso /  
weight  
**13,5 kg**



pezzi /  
pieces  
**9**



## PIANTA DRACAENA

DRACAENA  
PLANT

COD **SP2150124**

Pianta dracaena da interno in polietilene. 19 foglie.  
Vaso con muschio.

*Polyethylene indoor dracaena plant. 19 leaves. Pot with moss.*

**ALTEZZA**

60 cm



peso /  
weight  
**7 kg**



pezzi /  
pieces  
**6**



## PIANTA FICUS ELASTICA

FICUS ELASTICA  
PLANT

COD **SP2150543**

Pianta ficus elastica da interno in polietilene. 15 foglie.  
Vaso con muschio.

*Polyethylene indoor ficus elastica plant. 15 leaves. Pot with moss.*

**ALTEZZA**

65 cm



peso /  
weight  
**6 kg**



pezzi /  
pieces  
**6**







## PIANTA SANSEVIERIA

SANSEVIERIA  
PLANT

COD **SP2150075**

Pianta sansevieria da interno in polietilene. 21 foglie.  
Vaso con muschio.

*Polyethylene indoor sansevieria plant. 21 leaves. Pot with moss.*

**ALTEZZA** 75 cm

**Kg** peso /  
weight  
**13,5 kg**

**pezzi /  
pieces**  
**6**



## PIANTA FICUS LYRATA

FICUS LYRATA  
PLANT

COD **SP2150569**

Pianta ficus lyrata da interno in polietilene. 21 foglie.  
Vaso con muschio.

*Polyethylene indoor ficus lyrata plant. 21 leaves. Pot with moss.*

**ALTEZZA** 75 cm

**Kg** peso /  
weight  
**7 kg**

**pezzi /  
pieces**  
**4**



## PIANTA PALMA ARECA

ARECA PALM  
PLANT

COD **SP2150608**

Pianta palma areca da interno in polietilene. 9 foglie.  
Vaso con muschio.

*Polyethylene indoor areca palm plant. 9 leaves. Pot with moss.*

**ALTEZZA** 90 cm

**Kg** peso /  
weight  
**9,5 kg**

**pezzi /  
pieces**  
**6**



## PIANTA STRELITZIA

STRELITZIA  
PLANT

COD **SP2150597**

Pianta strelitzia da interno in polietilene. 5 foglie. Vaso con muschio.

*Polyethylene indoor strelitzia plant. 5 leaves. Pot with moss.*

**ALTEZZA** 100 cm



peso /  
weight  
**13 kg**



pezzi /  
pieces  
**6**



## PIANTA MONSTERA

MONSTERA  
PLANT

COD **SP2150623**

Pianta monstera da interno in polietilene. 24 foglie. Vaso con muschio.

*Polyethylene indoor monstera plant. 24 leaves. Pot with moss.*

**ALTEZZA** 120 cm



peso /  
weight  
**16 kg**



pezzi /  
pieces  
**4**



## PIANTA STRELITZIA

STRELITZIA  
PLANT

COD **SP2150598**

Pianta strelitzia da interno in polietilene. 12 foglie e 2 fiori. Vaso con muschio.

*Polyethylene indoor strelitzia plant. 12 leaves and 2 flowers. Pot with moss.*

**ALTEZZA** 120 cm



peso /  
weight  
**16 kg**



pezzi /  
pieces  
**4**





## PIANTA DRACAENA

*DRACAENA  
PLANT*

COD **SP2150125**

Pianta dracaena da interno in polietilene. 88 foglie.  
Vaso con muschio.

*Polyethylene indoor dracaena plant. 88 leaves. Pot with moss.*

**ALTEZZA** 130 cm

**Kg** peso /  
weight  
**17 kg**

**pezzi /  
pieces**  
**4**



## PIANTA FICUS LYRATA

*FICUS LYRATA  
PLANT*

COD **SP2150570**

Pianta ficus lyrata da interno in polietilene. 60 foglie.  
Vaso con muschio.

*Polyethylene indoor ficus lyrata plant. 60 leaves. Pot with moss.*

**ALTEZZA** 130 cm

**Kg** peso /  
weight  
**17 kg**

**pezzi /  
pieces**  
**4**



## PIANTA FICUS ELASTICA

*FICUS ELASTICA  
PLANT*

COD **SP2150544**

Pianta ficus elastica da interno in polietilene. 54 foglie.  
Vaso con muschio.

*Polyethylene indoor ficus elastica plant. 54 leaves. Pot with moss.*

**ALTEZZA** 145 cm

**Kg** peso /  
weight  
**11 kg**

**pezzi /  
pieces**  
**2**



## PIANTA PALMA ARECA

ARECA PALM  
PLANT

COD **SP2150609**

Pianta palma areca da interno in polietilene. 33 foglie.  
Vaso con muschio.

*Polyethylene indoor areca palm plant. 33 leaves. Pot with moss.*

**ALTEZZA** 160 cm



peso /  
weight  
**11 kg**



pezzi /  
pieces  
**2**



## PIANTA BANANO

BANANO  
PLANT

COD **SP2150515**

Pianta banano da interno in polietilene. 17 foglie.  
Vaso con muschio.

*Polyethylene indoor banano plant. 17 leaves. Pot with moss.*

**ALTEZZA** 170 cm



peso /  
weight  
**13 kg**



pezzi /  
pieces  
**4**



## PIANTA MONSTERA

MONSTERA  
PLANT

COD **SP2150624**

Pianta monstera da interno in polietilene. 16 foglie.  
Vaso con muschio.

*Polyethylene indoor monstera plant. 16 leaves. Pot with moss.*

**ALTEZZA** 170 cm



peso /  
weight  
**13 kg**



pezzi /  
pieces  
**2**







# PULIZIE E SANIFICAZIONE

*Cleaning and sanitization*



## ASPIRAPOLVERE CICLONICO

CORDLESS CYCLONIC  
VACUUM CLEANER

COD **SAS11PRO**

Aspirapolvere ciclonica senza filo con batteria ricaricabile 22,2 volt. Potenza 160 W. Fornita con beccuccio 2 in 1 e supporto a muro, per ricarica ed accessori. Non necessita di sacchetto poiché progettata con tecnologia ciclonica, per garantire maggiore potenza di aspirazione, comodità d'uso e risparmio economico. Il filtro HEPA garantisce uno dei migliori filtraggi durante la pulizia.

*Hoover equipped with a 22.2 volt rechargeable battery. Power 160 W. Supplied with a 2-in-1 spout and wall bracket for charging and accessories. It does not need a bag as it is designed with cyclonic technology, for more vacuum power, user comfort and economy. The HEPA filter guarantees the best filtration during cleaning.*

**MISURE**

l 22 x p 16 x h 77 cm



peso / weight  
**6 kg**



## ASPIRAPOLVERE CICLONICO CON MOTORE BRUSHLESS

CORDLESS BRUSHLESS MOTOR  
CYCLONIC VACUUM CLEANER

COD **SAS12PRO**

Aspirapolvere dotata di una batteria ricaricabile 22,2 volt, motore brushless senza filo con batteria ricaricabile. Potenza 160 W. Fornita con beccuccio 2 in 1 e supporto a muro, per ricarica ed accessori. Non necessita di sacchetto. Per una maggiore efficienza durante la pulizia, il funzionamento ciclonico è alimentato da un motore brushless: questo non ha bisogno di contatti elettrici tra le spazzole, ma il suo funzionamento è garantito da un rotore a magneti permanenti. Il filtro HEPA garantisce uno dei migliori filtraggi durante la pulizia.

*Vacuum cleaner equipped with a 22.2 volt rechargeable battery. Power: 160 W. Supplied with a 2-in-1 spout and wall support, for charging and accessories. It doesn't need a bag as it is designed with cyclonic technology for more vacuum power, ease of use and economy. For greater efficiency during cleaning, the cyclonic operation is powered by a brushless motor: this does not need any electrical contact between the brushes, but its operation is ensured by a permanent magnet rotor.*

**MISURE**

l 30,5 x p 12 x h 69 cm



peso / weight  
**6 kg**







## ASPIRAPOLVERE CON FILO SENZA SACCHETTO

*CORDED AND BAGLESS  
VACUUM CLEANER*

COD **SAS08HOME**

Aspirapolvere con tubo estensibile in alluminio e impugnatura ergonomica, per garantire comodità durante la pulizia. Cavo di 5 metri. Potenza 800 W. Non richiede sacchetto per la polvere, ma è dotato di un contenitore svuotabile. Il filtro HEPA, garantisce uno dei migliori filtraggi durante la pulizia.

*Vacuum cleaner with extendable aluminium hose and ergonomic handle for comfort during cleaning. 5 meters cable. Power 800 W. Does not require a dust bag, but is equipped with an emptyable container. HEPA filter, ensures best filtration during cleaning.*

**MISURE** | 138 x p 10 x h 55 cm

**Kg** peso / weight  
**6 kg**

## PULITRICE A VAPORE

*STEAM CLEANER*

COD **SXVAP0500**

Pulitrice a vapore con cavo extra-lungo 5 metri. Potenza 1050 W. In dotazione i seguenti accessori: adattatore angolare, accessorio in stoffa, adattatore di pulizia universale, spazzola rotonda e ugello vapore rotante 360°. Perfetto per ogni tipo di pulizia e angolatura, ottimizza al massimo la pulizia della propria abitazione.

*Steam cleaner with extra-long cable 5 meters. Power 1050 W. With the following accessories: angle adapter, cloth attachment, universal cleaning adapter and round brush. 360° rotating steam nozzle. Perfect for all types of cleaning and angles, optimising the cleaning of your home.*

**MISURE** | 125,2 x p 14,2 x h 23,5 cm

**Kg** peso / weight  
**2 kg**



ACCESSORIO  
IN STOFFA  
FABRIC ACCESSORY



ACCESSORI  
MULTIUSO  
MULTIPURPOSE ACCESSORY

## SANIFICATORE PORTATILE AD OZONO

PORTABLE  
OZONE AIR SANITIZER

COD **03ARIA10G**

Sanificatore maneggevole e portatile ad ozono per aria adatto a locali fino a 60 m<sup>2</sup>. Garantisce fino a 120 minuti di trattamento grazie al pratico timer.

Veloce, emette 10g di ozono all'ora. Efficace contro i virus in 15 min per 20 m<sup>2</sup>.

*Handy and portable ozone air sanitizer. Great for environments up to 60 m<sup>2</sup>. It guarantees up to 120 minutes of treatment, thanks to the practical timer. Fast, it ejects 10g of ozone per hour. Effective against viruses in 15 minutes for 20 metres square.*

**MISURE**

l 22 x p 16 x h 20 cm



peso / weight  
**2,4 kg**



## SANIFICATORE PORTATILE AD OZONO PER ARIA E ACQUA

PORTABLE OZONE SANITIZER  
FOR AIR AND WATER

COD **03ARIAACQUA10G**

Sanificatore portatile ad ozono per aria e acqua adatto a locali fino a 80 mq. Uniformità di produzione. Veloce distribuzione dell'ozono. Capacità di generazione ozono 10 g/h. Potenza 140 W. Elevata durabilità. Il display di questo modello ha timer digitale, visualizzazione della quantità di ozono prodotto e cicli continui programmabili. La macchina è corredata da un tubo flessibile che permette di sanificare l'acqua trasformandola in un disinfettante.

*Portable ozone sanitizer for air and water suitable for rooms up to 80 mq. Production uniformity. Faster ozone distribution. Ozone generation capacity 10 g/h. Power 140 W. High durability. This model display can count on digital timer, produced ozone quantity view and programmable continuous cycles. The machine is equipped with a flexible tube, which allows sanitizing water and transforming it in a sanitizer.*

**MISURE**

l 32 x p 25 x h 52,5 cm



peso / weight  
**8,4 kg**





## SANIFICATORE PORTATILE AD OZONO PER ARIA E ACQUA

PORTABLE OZONE SANITIZER FOR AIR AND WATER

COD **03ARIAACQUA30G**

Sanificatore portatile ad ozono per aria e acqua adatto a locali fino a 200 mq. Uniformità di produzione. Veloce distribuzione dell'ozono. Capacità di generazione ozono 30 g/h. Potenza 300 W. Elevata durabilità. Il display di questo modello ha timer digitale, visualizzazione della quantità di ozono prodotto e cicli continui programmabili. La macchina è corredata da un tubo flessibile che permette di sanificare l'acqua trasformandola in un disinfettante.

*Portable ozone sanitizer device for air and water suitable for spaces up to 200 mq. Production uniformity. Faster ozone distribution. Ozone generation capacity 30 g/h. Power 300 W. High durability. This model display can count on digital timer, produced ozone quantity view and programmable continuous cycles. The machine is equipped with a flexible tube, which allows sanitizing water and transforming it in a sanitizer.*

**MISURE**

l 40 x p 30 x h 73 cm



peso / weight  
**21 kg**

## DISPENSER PORTAGEL A INFRAROSSI

INFRARED GEL HOLDER DISPENSER

COD **SDISPENSER**

Dispenser portagel a infrarossi da muro o da piantana. Ricaricabile con rabbocco dall'alto. Venduto singolarmente.

*Infrared gel holder dispenser for wall or upright. Rechargeable from above. Individually sold.*

**MISURE**

l 12,5 x p 11 x h 26,5 cm



capacità / gross  
**1 Lt**



## DISPENSER AUTOMATICO DI COPRISCARPE

AUTOMATIC DISTRIBUTOR  
OF SHOE COVER

COD **DIST-RICCS**

Consente l'inserimento del copriscarpe senza abbassarsi e senza toccare nulla. Posizionando il piede nel contenitore, il copriscarpe si avvolge automaticamente alla scarpa. Contenitore in alluminio, acciaio e plastica con pratica maniglia per il trasporto. Capacità caricamento: 50 pezzi in totale. Il pacchetto include 1 distributore + 10 confezioni da 100 di ricarica.

*Allow insertion of shoe cover without lowering and without touching anything. The shoe cover automatically wraps around the shoe by placing the foot in the container. Loading capacity: 50 pieces overall. The package includes 1 CS distributor and 10 packs of 100 of CS refil.*

**MISURE** | 46,2 x p 24 x h 16,2 cm



+ 10 CONFEZIONI  
DA 100 DI RICARICA  
+ 10 PACKS OF 100  
OF CS REFIL



## DISPENSER AUTOMATICO DI COPRISCARPE

AUTOMATIC DISTRIBUTOR  
OF SHOE COVER

COD **DISTRIBUTORECS**

Consente l'inserimento del copriscarpe senza abbassarsi e senza toccare nulla. Posizionando il piede nel contenitore, il copriscarpe si avvolge automaticamente alla scarpa. Contenitore in alluminio, acciaio e plastica con pratica maniglia per il trasporto. Capacità caricamento: 50 pezzi in totale.

*Allow insertion of shoe cover without lowering and without touching anything. The shoe cover automatically wraps around the shoe by placing the foot in the container. Loading capacity: 50 pieces overall.*

**MISURE** | 46,2 x p 24 x h 16,2 cm





## RICARICA COPRISCARPE

REFIL  
SHOE COVER

COD **RICARICACS**

Ricarica di copriscarpe universali usa e getta. Copriscarpe PE con attacco O-type. Confezione da 100 pezzi.

*Refil shoe cover. PE shoe cover with O-type attack. Package of 100 pieces.*



## TERMOMETRO SCANNER LASER

SCANNER LASER  
THERMOMETER

COD **TER3COLORI**

Termometro con display a 3 colori. Verde fino 37°C, giallo (37,4 - 38,0°C), rosso (38,1 - 42,9°C). Range temperatura 34,0-42,9°C. Precisione di misurazione:  $\pm 0,2$ . Distanza di misurazione 3-5 cm. Tempo di misurazione: 0,5 s. Spegnimento automatico dopo 15 s. Storico delle ultime 32 temperature. Tensione di alimentazione: DC3V AAA \* 2.

*3 colors thermometer with display. Green up to 37°C, yellow (37,4 - 38°C), red (38,1 - 42,9°C). Temperature range 34,0-42,9°C - Measurement accuracy:  $\pm 0,2$ . Measuring distance 3-5 cm - Measuring time 0,5 s. Automatic shutdown 15 s. Last 32 measured temperatures. Supply voltage: DC3V AAA\*2.*



# PICCOLI ELETTRODOMESTICI

*Small appliances*



## FORNO ELETTRICO DA 12 LITRI

ELECTRIC OVEN,  
12 LITERS

COD **SF01209**

Forno elettrico con timer max 60 min e funzioni di cottura. Un forno piccolo ma super efficiente. Potenza: 650 W. Il forno è già dotato di teglie in alluminio e griglie in acciaio inox. La struttura delle griglie, previene il deterioramento dopo il lavaggio, garantendo un uso duraturo.

*Electric oven with max. 60 min timer and cooking functions. A small but super-efficient oven. Power: 650 W. The oven is already equipped with aluminium baking trays and stainless steel grills. The structure of the grills prevents deterioration after washing, ensuring long-lasting use.*

**MISURE** | 36,8 × p 31 × h 25,2 cm

 capacità / capacity  
**12 lt**



## FORNO ELETTRICO DA 20 LITRI

ELECTRIC OVEN,  
20 LITERS

COD **SF02006**

Forno elettrico con timer max 60 min e funzioni di cottura. Un forno piccolo ma super efficiente. Potenza: 1280 W. Il forno è già dotato di teglie in alluminio e griglie in acciaio inox. La struttura delle griglie previene il deterioramento dopo il lavaggio, garantendo un uso duraturo.

*Electric oven with max 60 min timer and cooking functions. A small but super-efficient oven. Power: 1280 W. The oven is already equipped with aluminium baking trays and stainless steel grills. The design of the grills prevents deterioration after washing, ensuring long-lasting use.*

**MISURE** | 40,3 × p 31,4 × h 25,7 cm

 capacità / capacity  
**20 lt**







## FORNO ELETTRICO VENTILATO DA 40 LITRI

*ELECTRIC FAN OVEN,  
40 LITERS*

COD **SFOV4015**

Forno elettrico ventilato con timer max 60 min e funzioni di cottura. Un forno piccolo ma super efficiente. Potenza: 1500 W. Il forno è già dotato di teglie in alluminio e griglie in acciaio inox. La struttura delle griglie previene il deterioramento dopo il lavaggio, garantendo un uso duraturo.

*Electric oven with max 60 min timer and cooking functions. A small but super-efficient oven. Power 1500 W. The oven is already equipped with aluminium baking trays and stainless steel grills. The design of the grills, prevents deterioration after washing, ensuring long-lasting use.*

**MISURE** | 153,6 × p 36,8 × h 31 cm

 capacità / capacity  
**40 lt**



## FORNO ELETTRICO VENTILATO A PARETI FREDDE DA 28 LITRI

*ELECTRIC FAN-ASSISTED  
COLD-WALL OVEN, 28 LITERS*

COD **SFOK2812L**

Forno elettrico ventilato a pareti fredde con timer max 90, doppie cerniere per una chiusura più stabile e pareti (interne antiaderenti ed esterne fredde) con certificazione EK1. Dispone di 6 funzioni di cottura. Potenza: 1500 W. Il forno è già dotato di teglie in alluminio e griglie in acciaio inox. La struttura delle griglie previene il deterioramento dopo il lavaggio, garantendo un uso duraturo.

*Electric oven with max 90 timer, double hinges for a more stable closure and walls (non-stick inside and cool outside) with EK1 certification. Features 6 cooking functions. Power 1500 W. The oven is already equipped with aluminium baking trays and stainless steel grills. The design of the grills preventing deterioration after washing and ensuring long-lasting use.*

**MISURE** | 147 × p 30 × h 40 cm

 capacità / capacity  
**28 lt**



## FORNO ELETTRICO VENTILATO A PARETI FREDDE DA 36 LITRI

ELECTRIC FAN-ASSISTED  
COLD-WALL OVEN, 36 LITERS

COD **SFOK3612**

Forno elettrico ventilato a pareti fredde con timer 90 minuti max e pareti (interne antiaderenti ed esterne fredde) con certificazione EK1. Offre 6 funzioni di cottura tra cui quella di friggitrice ad aria. Potenza: 2000 W. Il forno è già dotato di teglie in alluminio e griglie in acciaio inox. La struttura delle griglie previene il deterioramento dopo il lavaggio, garantendo un uso duraturo.

*With 90-minute max. timer and walls (non-stick interior and cool exterior) with EK1 certification. It has 6 cooking functions including air frying. Power: 2000 W. The oven is already equipped with aluminium baking trays and stainless steel grills. The design of the grills preventing deterioration after washing and ensuring long-lasting use.*

**MISURE** 149,5 × p 41,5 × h 31,5 cm

capacità / capacity  
**36 lt**



## FORNO ELETTRICO VENTILATO A PARETI FREDDE DA 50 LITRI

ELECTRIC FAN-ASSISTED  
COLD-WALL OVEN, 50 LITERS

COD **SFOK5012**

Forno elettrico ventilato a pareti fredde con timer 90 minuti max e pareti (interne antiaderenti ed esterne fredde) con certificazione EK1. Offre 6 funzioni di cottura. Potenza 2000 W. Il forno è già dotato di teglie in alluminio e griglie in acciaio inox. La struttura delle griglie previene il deterioramento dopo il lavaggio, garantendo un uso duraturo.

*With 90-minute max timer, and walls (non-stick interior and cool exterior) with EK1 certification. It has 6 cooking functions. Power 2000 W. The oven is already equipped with aluminium baking trays and stainless steel grills. The design of the grills preventing deterioration after washing and ensuring long-lasting use.*

**MISURE** 155,7 × p 34,9 × h 44,8 cm

capacità / capacity  
**50 lt**





## FORNO ELETTRICO VENTILATO A PARETI FREDDE DA 50 LITRI

*ELECTRIC FAN-ASSISTED  
COLD-BLAST OVEN WITH AIR  
FRYER FUNCTION, 50 LITERS*

COD **SFOK5112R**

Forno elettrico ventilato a pareti fredde da 50 litri con funzione friggitrice ad aria con timer max 90, doppie cerniere per una chiusura più stabile e pareti (interne antiaderenti ed esterne fredde) con certificazione EK1. Dispone di 6 funzioni di cottura, tra cui quella di friggitrice ad aria. Potenza 2000 W. Il forno è già dotato di teglie in alluminio e griglie in acciaio inox. La struttura delle griglie previene il deterioramento dopo il lavaggio, garantendo un uso duraturo.

*With a timer up to 90 minutes, double hinges for a more stable closure (non-stick interior walls and cool exterior walls) and EK1 certification. It has 6 cooking functions including air fryer. Power 2000 W. The oven is already equipped with aluminium baking trays and stainless steel grills. The design of the grills prevents deterioration after washing, providing long-lasting use.*

**MISURE** | 155.7 × p 44.8 × h 34.8 cm

 capacità / capacity  
**50 lt**

## FORNO ELETTRICO VENTILATO A PARETI FREDDE DA 65 LITRI

*ELECTRIC FAN-ASSISTED  
COLD-BLAST OVEN WITH AIR  
FRYER FUNCTION, 65 LITER*

COD **SFOK6512R**



Con timer max 90 min, doppie cerniere (per una chiusura più stabile) e pareti fredde certificate EK1. Presenta 6 funzioni di cottura, tra cui anche funzione girarrosto e friggitrice ad aria. Potenza: 2000 W. Il forno è già dotato di teglie in alluminio e griglie in acciaio inox. La struttura delle griglie previene il deterioramento dopo il lavaggio, garantendo un uso duraturo.

*With max. 90 min timer, double hinges (for more stable closing) and EK1-certified cold walls. It has six cooking functions, including a roaster and air fryer function. Power: 2000 W. The oven is already equipped with aluminium baking trays and stainless steel grills. The design of the grills preventing deterioration after washing and ensuring long-lasting use.*

**MISURE** | 162.6 × p 45 × h 36.6 cm

 capacità / capacity  
**65 lt**



## FORNO A MICROONDE DA 20 LITRI

MICROWAVE OVEN  
20 LITERS

Forno a microonde con 8 programmi cottura e 5 livelli di potenza. Vetro semispecchiato. Diametro del piatto rotante: 24,5 cm. Potenza: 800 W. Disponibile in nero e bianco.

*Microwave oven with 8 cooking programmes and 5 power levels. Semi-mirrored glass. Turntable diameter: 24.5 cm. Power: 800 W. Available in black and white.*

### MISURE

l 29,7 × p 21 × h 29,6 cm



capacità /  
capacity  
**20**

## TEGLIA IN ACCIAIO PER FORNO 28 LITRI

STEEL BAKING TRAY  
FOR OVEN 28 LITERS

COD **SFOK28TR**

Teglia in acciaio di ricambio per forno elettrico. Compatibile con forno SFOK2812L.

*Replacement steel baking tray for electric oven. Compatible with SFOK2812L oven.*

### MISURE

l 33 x p 30,8 cm



○ BIANCO - COD **SFOM200B**

● NERO - COD **SFOM201N**





## TEGLIA IN ACCIAIO PER FORNO 36 LITRI

STEEL BAKING TRAY  
FOR OVEN 36 LITERS

COD **SFOK36TR**

Teglia in acciaio di ricambio per forno elettrico.  
Compatibile con forno SFOK3612.

*Replacement steel baking tray for electric oven. Compatible with SFOK3612 oven.*

**MISURE**

l 33,5 x p 36 cm



## TEGLIA IN ACCIAIO PER FORNO 50 LITRI

STEEL BAKING TRAY  
FOR OVEN 50 LITERS

COD **SFOK50TRAY**

Teglia in acciaio di ricambio per forno elettrico.  
Compatibile con forno SFOK5012/SFOK5112R.

*Replacement steel baking tray for electric oven. Compatible with SFOK5012/SFOK5112R oven.*

**MISURE**

l 36,8 x p 41,5 cm



## TEGLIA IN ACCIAIO PER FORNO 65 LITRI

STEEL BAKING TRAY  
FOR OVEN 65 LITERS

COD **SFOK65TRAY**

Teglia in acciaio di ricambio per forno elettrico.  
Compatibile con forno SFOK6512.

*Replacement steel baking tray for electric oven. Compatible with SFOK6512 oven.*

**MISURE**

l 36,6 x p 48 cm



## IMPASTATRICE DA 5 LITRI

MIXER, 5 LITERS

Impastatrice a 6 velocità di rotazione planetaria con funzione "Pulse". Permette di lavorare qualsiasi impasto, anche i più complicati. Potenza 1200 W. Con coperchio paraschizzi e testa sollevabile. In dotazione 1 frusta d'acciaio, gancio impastatore e sbattitore in teflon. Tutti gli accessori prevengono il deterioramento dopo il lavaggio, garantendo un uso duraturo. Grazie alle fruste in teflon, l'efficacia e la durabilità aumentano anche dopo il lavaggio in lavastoviglie. Disponibile in due colorazioni: bianco o rosso.

*6 speed planetary mixer with "Pulse" function. Allows you to knead any dough, even the most complicated. Power 1200 W. With splash guard cover and liftable head. Supplied with 1 steel beater, dough hook, teflon whisk. All accessories prevent deterioration after washing, ensuring long-lasting use; thanks to the teflon whisk, the effectiveness and durability is increased even after washing in the dishwasher. Available in two colors: white or red.*

### MISURE

p 52,5 × l 31 × h 39 cm



capacità /  
capacity  
**5 lt**



● ROSSO - COD **SIP5025R**

○ BIANCO - COD **SIP5025W**



## IMPASTATRICE DA 7 LITRI CON IMPUGNATURA

MIXER WITH HANDLE,  
7 LITERS

COD **SIP6750**

Impastatrice a 10 velocità di rotazione planetaria con funzione "Pulse". Permette la lavorazione di qualsiasi impasto, anche i più complicati. Potenza 1200 W. Con coperchio paraschizzi, testa sollevabile e impugnatura ergonomica, che facilita lo spostamento e la sistemazione. In dotazione 1 frusta d'acciaio, gancio impastatore e sbattitore in teflon. Tutti gli accessori prevengono il deterioramento dopo il lavaggio, garantendo un uso duraturo. Grazie alle fruste in teflon, l'efficacia e la durabilità, aumenta anche dopo il lavaggio in lavastoviglie.

*10 speed planetary mixer with "Pulse" function. Allows processing of any dough, even the most complicated. Power 1200 W. With splash guard cover, liftable head and ergonomic handle for easy movement and storage. Supplied with 1 steel beater, dough hook, teflon whisk. All accessories prevent deterioration after washing, ensuring long-lasting use. Thanks to the teflon whisk, the efficiency and durability is increased even after washing in the dishwasher.*

### MISURE

p 52,5 × l 31 × h 39 cm



capacità /  
capacity  
**7 lt**









# CATERING

*Catering*





## TAVOLO TONDO PIEGHEVOLE Ø152 CM

ROUND FOLDING TABLE Ø152 CM

COD **TP-152**

<b>MISURE</b>	h 74 / ø 152 cm
<b>DIAMETRO TUBI</b>	28x1 mm

Tavolo rotondo bianco in plastica HDPE con struttura in metallo verniciato. Pieghevole e facilmente trasportabile.

*Round white table made of HDPE plastic with varnished metal structure. It's folding and easily transportable.*

 pezzi / pieces  
**1**



## TAVOLO TONDO PIEGHEVOLE Ø183 CM

ROUND FOLDING TABLE Ø183 CM

COD **TP-183**

<b>MISURE</b>	h 74 / ø 183 cm
<b>DIAMETRO TUBI</b>	32x1 mm

Tavolo rotondo bianco in plastica HDPE con struttura in metallo verniciato. Pieghevole e facilmente trasportabile.

*Round white table made of HDPE plastic with varnished metal structure. It's folding and easily transportable.*

 pezzi / pieces  
**1**



- VERDE - COD **SG1526005**
- BIANCO - COD **SG1526004**

## GAZEBO POP-UP 3x3 M

POP-UP GAZEBO 3x3 M

Struttura pieghevole in acciaio con copertura in poliestere 160 gr/m<sup>2</sup>. Completo di borsa per trasporto.

*Folding steel frame with 160 gr/m<sup>2</sup> polyester cover. Complete with carrying bag.*

 peso / weight  
**13 kg**

 volume / volume  
**0,049 m<sup>3</sup>**

 pezzi / pieces  
**1**

<b>MISURE</b>	h 270 x p 300 x l 300 cm
---------------	--------------------------



## TAVOLO QUADRATO PIEGHEVOLE + SEDIE

SQUARE FOLDING TABLE + CHAIRS

COD **SS1815086**

Struttura in acciaio verniciato con vernici epossidiche color antracite, top in HDPE di colore antracite, set pieghevole composto da un tavolo quadrato e quattro sedie.

*Anthracite grey varnished steel structure with HDPE table top, set composed of one square table and four folding chairs.*

 peso / weight  
**15 kg**

 volume / volume  
**0,147 m<sup>3</sup>**

 pezzi / pieces  
**1 set**

<b>TAVOLO</b>	h 73 x p 86 x l 86 cm
<b>SEDIE</b>	h 80 x p 36 x l 41 cm





- NOCE - COD **SS1714196**
- BIANCO - COD **TS1714186**

## SEDIA PIEGHEVOLE

FOLDING CHAIR

**MISURE**

h 88 x p 50 x l 45 cm

Struttura in acciaio verniciato con vernici epossidiche. Top con schienale in HDPE pieghevole. Colori disponibili: struttura grigia e top bianco (cod TS1714186), struttura e top color noce (cod SS1714196).

*Steel structure painted with epoxy paint. Folding HDPE top. Available colors: grey structure and white seat (cod TS1714186), brown structure and seat (cod SS1714196).*

 peso / weight  
**20 kg**

 volume / volume  
**0,144 m<sup>3</sup>**

 pezzi / pieces  
**4**



- NOCE - COD **SS1714197**
- BIANCO - COD **SS1714187**

## SGABELLO PIEGHEVOLE

FOLDING STOOL

**MISURE**

h 44 x p 30 x l 30 cm

Struttura in acciaio verniciato con vernici epossidiche. Top in HDPE pieghevole. Colori disponibili: struttura grigia e top bianco (cod SS1714187), struttura e top color noce (cod SS1714197).

*Steel structure painted with epoxy paint. Folding HDPE top. Available colors: grey structure and white seat (cod SS1714187), brown structure and seat (cod SS1714197).*

 peso / weight  
**10 kg**

 volume / volume  
**0,086 m<sup>3</sup>**

 pezzi / pieces  
**6**



- NOCE - COD **SP1714195**
- BIANCO - COD **SP1714185**

## PANCA RETTANGOLARE PIEGHEVOLE

FOLDING BENCH

<b>MISURE</b>	h 44 x p 30 x l 183 cm
---------------	------------------------

Struttura in acciaio verniciato con vernici epossidiche e top in HDPE pieghevole. Chiusura a valigia facile da trasportare. Colori disponibili: struttura grigia e top bianco (cod SP1714185), struttura e top color noce (cod SP1714195).

*Steel structure painted with epoxy paint and folding HDPE top. Easy-to-carry case closure. Available colors: grey structure and white seat (cod SP1714185), brown structure and seat (cod SP1714195).*

 peso / weight  
**8,6 kg**

 volume / volume  
**0,029 m<sup>3</sup>**

 pezzi / pieces  
**1**



- NOCE - COD **ST1714193**
- BIANCO - COD **ST1714183**

## TAVOLO RETTANGOLARE PIEGHEVOLE

RECTANGULAR FOLDING TABLE

<b>MISURE</b>	h 74 x p 76 x l 183 cm
---------------	------------------------

Struttura in acciaio verniciato con vernici epossidiche e top in HDPE pieghevole. Colori disponibili: struttura grigia e top bianco (cod ST1714183), struttura e top color noce (cod ST1714193).

*Varnished steel folding structure with HDPE table top. Available colors: grey structure and white seat (cod ST1714183), brown structure and seat (cod ST1714193).*

 peso / weight  
**14 kg**

 volume / volume  
**0,070 m<sup>3</sup>**

 pezzi / pieces  
**1**





[www.stark-horeca.com](http://www.stark-horeca.com)





**Stark s.r.l.**

42017 Novellara, (RE) Italy - Via Provinciale Nord, 36  
Tel. 0039 0522 653745 - [info@starksafes.com](mailto:info@starksafes.com) - [www.stark-horeca.com](http://www.stark-horeca.com)